

YMP Series



User Manual

Special Drive for Multi-pumps Water Supply



Thank you for choosing the general-purpose inverter of YMP series of multi-functions and high performance made by YILMAZ REDÜKTÖR AŞ

In order to make use of the functions full on the Inverter and ensure safety of user, please read this instruction carefully before installing, running, maintaining and checking Inverter.

This instruction divides safety cautions into Danger and Warning, please pay special attention to the symbols “ Danger” and “ Warning” and their related content.

The symbol “ Danger ” indicates incorrect operation, which can cause death or serious injury to personnel.

The symbol “ Warning” indicates incorrect operation, which can cause personnel injury or Inverter and mechanical system fault, as determined by different situations, the caution affairs may lead to serious consequence.

The figures in this instruction are for convenience with descriptions; they may have slight differences compared to the products, and the products update can also cause slight differences between the figures and products, the actual sizes are subject to actual products. Please notice that this operational instruction shall be delivered to the end user, and be kept appropriately for further use of inspecting and maintaining.

If you have questions, please contact us or our agents in time, you will always receive our best attention.

TABLE OF CONTENTS

Chapter 1 Safety Cautions	1
1-1 Confirmation on Receiving	1
1-2 Moving and Installation	1
1-3 Wiring and Junction	2
1-4 Power on and Commissioning	4
1-5 Check and Maintenance	5
1-6 Exception Processing.....	5
1-7 Scrapping Processing	6
Chapter 2 Product Introduction	7
2-1 Unpacking inspection	7
2-2 Inverter model description.....	7
2-3 Product specifications	7
2-4 Product series models	9
2-5 Product storage	10
Chapter 3 Installation of Inverter	11
3-1 Installation environment and requirements	11
3-2 The outline and installation size	13
3-3 The Hole size of the tray for the operating panel	14
Chapter 4 Wiring	15
4-1 Main loop wiring	15
4-1-1 External Components Description	15
4-1-2 Main Loop Wiring Notice	17
4-1-3 Recommending Equipment Specifications.....	18

4-1-4 Main loop terminals and description	19
4-2 Control terminal.....	21
4-2-1 Basic wiring diagram	21
4-2-2 Control terminals arrangement	23
4-2-3 Control terminal description	23
4-2-4 Control Loop Wiring Notice	24
Chapter 5 Running	25
5-1 Digital Operating Panel	25
5-1-1 Key function description	25
5-1-2 LED indicator light description	26
5-1-3 Display Description	26
5-2 Operational Instruction of Digital Operating panel	27
5-3 Simple Running and Relative Items	30
5-3-1 Setup, installation and wiring	30
5-3-2 Wiring inspection	31
5-3-3 Parameter setup.....	31
5-3-4 Running	31
Chapter 6 Table of Functional Parameters.....	32
Chapter 7 Detailed Explanations of Parameters.....	46
7-1 Parameters for Monitoring.....	46
7-2 Parameters for basic running	50
7-3 Parameters of basic applications	61
7-4 Parameters for input and output application	68
7-5 Auxiliary application group	84
7-6 Application function group	94
7-7 Auxiliary application group (PID).....	101
7-8 Communication parameter group.....	113
7-9 Parameters for Advanced Application	120

Chapter 8 Maintenance, Fault Diagnosis and Countermeasure.	123
8-1 Daily checking items	123
8-2 Maintenance and checking notice.....	123
8-3 Regular checking items.....	123
8-4 Regular Replacement	124
8-5 Protective Information, Fault Diagnosis and Remove.....	124
8-6 Remove Regular Error	128
8-7 Disturbance solution.....	130
8-8 Failure Records.....	132
Chapter 9 External Fittings Selection.....	133
9-1 The Purpose of Accessory	133
9-2 Arrangement.....	133
9-2-1 DC reactor.....	133
9-2-2 AC reactor	134
9-2-3 Braking resistance.....	135
Appendix 1 Simple Application Example	137
1-1 Example	137
1-2 Multi control function of YMP.....	138
Appendix 2 Description of communication mode.....	141
2-1. ASCII mode.....	141
2-2. RTU mode.....	141
2-3 Description of Register Address:	142
2-4 Data address	142
2-4-1 Sample of using ASCII mode:	143
Appendix 3 Common parameters for YMP series drives.....	145

Chapter 1 Safety Cautions

1-1 Confirmation on Receiving

Warning

All the products have gone by strictly checking and testing before delivery, but considering transportation, please verify:

- Whether Inverter is distorted or damaged during transportation, do not install broken Inverter, and it may cause personnel injury, please inform our agent in time.
- Whether the package is integrated, accessories and user's instruction are contained, especially the user's instruction and guarantee card, please keep those for reference of further maintenance
- Whether the product is in accordance with the specifications, and whether there are unusual phenomena inside or outside Inverter.

1-2 Moving and Installation

Warning

- When moving the product, please use proper moving instruments to prevent Inverter from damage.
- When moving Inverter, please fasten the bottom of Inverter, holding the cover plate directly may lead to dropping and cause personnel injury or Inverter damaged.
- Please do not install Inverter on combustible substance, installing the convert directly on the combustible substance or near to combustible material may cause fire accident.
- Please verify whether installation of Inverter is correct.

- Please choose a safe location to install Inverter, and operation environment is shown as follows.

Ambient temperature: -10°C - 40°C (non-freezing).

Ambient humidity: max. 95% relative humidity (non-condensing)

Ambient environment: indoors, (no corrosive gas, combustible gas, oil mist and dust. Please keep off sunlight).

Altitude: lower than 1000m

Vibration: max. 0.5G

- Please make sure that the mounted substance can load with Inverter's weight and prevent it from falling, and make sure that the installation site is safe and reliable. Do not allow children and unauthorized personnel approaching Inverter.
- Please make sure that the screws are fixed, fastened and locked firmly in accordance with user's instruction of the manual, to prevent Inverter from falling.
- During installation, prevent screws, wire pieces and other electricity conductive material from falling in Inverter. Otherwise, Inverter may be damaged, or a serious accident may take place.
- If two and more Inverter is installed in one control cabinet, please install them according to the instruction of the manual. It is required to keep enough space, and add extra heat sinkers for airflow in the cabinet. That will lower 40°C of the temperature in the cabinet. Overheating may cause Inverter broken, fire or other accident.
- Inverter shall be installed by professional personnel.

1-3 Wiring and Junction

 **Warning**

- Please do not damage the wires. Let the wires bear weight or be

clamped may damage the wires and cause an electric shock.

- Do not install the phase-shifting capacitor, surge absorber or noise filter in output terminal of Inverter, otherwise may cause Inverter fault.
- Do not install switch devices in the output terminal of Inverter such as the air switch and contactor. If it is for technologic demand, please ensure that Inverter is switching without output.
- Please wire separately power wire and control wire for preventing interference.

 **Danger**

- Please ensure that the power is off before Junction.
- The wiring work shall be done by qualified electricians.
- Please wire in accordance with the user's instruction of the manual.
- The grounding connection shall be installed properly in accordance with relative regulations in the user's instruction. Otherwise it may cause an electric shock or fire.
- Please use independent power supply for Inverter. Never use the same power supply with strong interference equipment like electric welder.
- Please do not touch the bottom plate with wet hand. Otherwise you may get an electric shock.
- Please do not touch the terminal directly. Do not connect with Inverter input/output cables with the cover panel. Otherwise you may get an electric shock.
- Please make sure that voltage of the power supply and voltage of Inverter are the same, otherwise it may cause Inverter fault or personnel injury.
- Please make sure that power supply connects with the R•S•T terminal but without the U.V.W terminal, otherwise it may cause

the internal fault of Inverter.

- Please do not test Inverter on pressure resistance. Otherwise it may cause the internal fault of Inverter.
- Please install accessories such as brake units, brake resistors in accordance with the user's instruction; otherwise it may cause Inverter fault or fire.
- Please ensure that the screws of the terminals are firmly locked, otherwise it may cause Inverter fault.

1-4 Power on and Commissioning

Warning

- Please ensure that the front cover is installed before the power is on. During the power transmission, please do not remove the cover.
- Please ensure that the power cables and signal cables are connected correctly, otherwise it may cause Inverter damaged.
- Please ensure all of the parameters are set correctly before running.
- Before running, please ensure machine not to damage running equipments. It is recommended to take running with idle load.
- Please provide an emergency stop switch when stop function setting is unavailable.
- Do not use electromagnetic contactor to start up and shut down Inverter, otherwise it may affect the life of Inverter

Danger

- When fault restart function is set. Please do not approach equipment because the equipment may automatically restart after running stop.
- Please verify the use range of motors and machines. Exceeding their use range will cause motor and machine fault.
- Please do not change the parameter settings of Inverter casually during running.

- Please do not touch the heat sink and brake resistor, otherwise you may get burned.
- Do not use wet hands to touch bottom plate and to operate switches and keys. Otherwise you may get an electric shock or injury.
- Please do not link or withdraw motors during Inverter running, otherwise it may cause Inverter protected or fault.

1-5 Check and Maintenance

Warning

- Please ensure that the power and indicating light is off before checking and maintaining. Otherwise, you may get an electric shock.
- Before checking and maintaining, please touch a nearby metal substance with your hand to eliminate the static electricity for preventing Inverter from damage caused by static electricity.
- Please do not use Megohmmeter (insulation resistance) to test the control circuit of Inverter.

Danger

- Only authorized professional personnel can do check, maintenance and replacement of the components, no other people are allowed.
- Please do check, maintenance and replacement of the components according to appointed methods in the user's instruction, strictly prohibit modifying by your own. If you do so, you may get an electric shock and injury or Inverter may get damaged.

1-6 Exception Processing

Danger

- When the protection in Inverter is on, please follow the fault

display of Inverter to find out causes and eliminate the fault, then reset and restart Inverter. If the fault is not eliminated. Resetting and restarting Inverter can cause Inverter s or machine fault.

- When Inverter fault takes place, please do not treat it by your own, and contact our company and our distributors.

1-7 Scrapping Processing



Warning

When Inverter is scrapped, please dispose it as industrial rubbish, do not burn it up.

Chapter 2 Product Introduction

2-1 Unpacking inspection

In unpacking, please confirm the following:

- Check whether the model type of Inverter is in accordance with your order.
- Check whether Inverter is damaged and related accessories are completed.

If you find an omission or disagreement, please contact the suppliers.

2-2 Inverter model description



Model: NZ C 0055 - T4 - B - Y

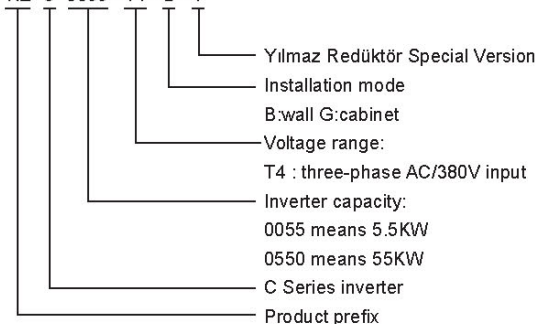

2-3 Product specifications

Items	Description	
Input	Rated Voltage, Frequency	Three-phase 380V 50/60Hz; one-phase 220V 50/60Hz
	Allowed Voltage Range	380V: 330~440V; one-phase 220V: 170V~240V
Output	Voltage	380V: 0~380V; one-phase 220V: 0~220V
	Frequency	0.10~400.0Hz
Control mode		Space vector, V/F control
Display		Five-digit LED display, Indicator display; Display setup frequency, Output frequency, Output current, DC voltage, Module temperature, Running state, and fault
Control Characteristics	Output Frequency Range	0.10Hz~400.00Hz
	Frequency Setup Definition	Digital setting: 0.01 Hz. Analog setup: 0.1% of maximum output frequency
	Output Frequency Accuracy	0.01Hz
	V/F Control	Setting V/F curve can satisfy various load requirements.
	Torque Control	Auto increase: auto raise torque by loading condition; Manual increase: enable to set 0 to 20 % of raising torque
	Multifunctional Input Terminal	8 multi-function input, take 15 speed control, process, 4 acceleration/deceleration speed, up and down function, scram
	Multifunctional Output Terminal	Three multi-function output take working, zero speed, external fault, signal and alarm
	Accel. /decel. Time Setup	0~6000s acceleration/deceleration time can be respectively set.
Other Functions	PID Control	Built-in PID control
	RS485	Standard RS485 communication function (MODBUS)
	Frequency Setup	Analog 0~10V, 0~20mA, direct set operating panel, RS485 specify value, up/down specify value.

Items	Description	
Other Functions	Multiple Speed	Eight multifunctional input terminals, 15 section speed can be set
	Auto Stabilizer	Option for auto Stabilizer
	Counter	Built-in 2 group of Counters
Protection Function	Overload	Constant torque 150% 1 minute, blowing machine 120% 1 minute
	Over Voltage	Over voltage protection can be set.
	Under Voltage	Under voltage protection can be set.
	Others	Overheat protection, short-circuit protection, over current protection and parameter lock
Environment	Temperature	-10°C to 40°C (non-freezing)
	Humidity	Max. 95% (non-condensing)
	Altitude	Under 1000m
	Vibration	Max. 0.5G
Structure	Cooling mode	Compulsory cooling
	Protection Level	IP 20
Installation	Mode	Below 132 KW wall mounted 160-350 KW wall mounted or in cabinet Above 400 KW in cabinet

2-4 Product series models

MODEL	Output power	Capacity KVA	Output Current (A)	Overload capacity (60s)	Applicable motor KW
NZC0055T4B-Y	5.5	10	12.5	15	5.5
NZC0075T4B-Y	7.5	14	17.5	21	7.5
NZC0110T4B-Y	11	19	24	28.8	11
NZC0150T4B-Y	15	26	33	39.6	15
NZC0180T4B-Y	18.5	32	40	48	18.5
NZC0220T4B-Y	22	37	47	56.4	22
NZC0300T4B-Y	30	52	65	78	30
NZC0370T4B-Y	37	64	80	96	37
NZC0450T4B-Y	45	72	90	108	45

MODEL	Output power	Capacity KVA	Output Current (A)	Overload capacity (60s)	Applicable motor KW
NZC0550T4B-Y	55	84	110	132	55
NZC0750T4B-Y	75	115	152	182.4	75
NZC0900T4B-Y	90	135	176	264	90
NZC1100T4B-Y	110	160	210	252	110
NZC1320T4B(G)-Y	132	193	255	306	132
NZC1600T4B(G)-Y	160	230	305	366	160
NZC1850T4B(G)-Y	185	260	340	408	185
NZC2000T4B(G)-Y	200	290	380	456	200
NZC2200T4B(G)-Y	220	320	425	510	220
NZC2500T4B(G)-Y	250	365	480	576	250
NZC2800T4B(G)-Y	280	427	530	636	280

2-5 Product storage

Inverter must be put in the package before installation. If Inverter is not used for the moment, during the storage, please pay attention to those as below:

- A. The products must be placed in the dry and dust-free location.
- B. The relative humidity of the environment is within 0~95%, and without condensing.
- C. Storage temperature of environment must be within the range of -26°C to +65°C.
- D. There are no corrosive gas and liquid in the storage environment, and avoid exposing the product directly to the sunlight.

It is better not to store Inverter for a long time. Long term storage can lead to the deterioration of the electrolytic capacitor. If it is necessary to store Inverter for a long time, please notice that make sure Inverter is electrified at least once not less than 5 hours per year. In operation, use voltage regulator to input current, the voltage increases gradually to the rated voltage.

Chapter 3

Installation of Inverter

3-1 Installation environment and requirements

Environment of installation has direct effect on the life span and usage of Inverter. If Inverter is used in the environment that does not accord with allowed range of the operational instruction, and may lead to Inverter protection or fault.

Inverter shall be mounted on the wall. Please install it vertically for convection, and heat venting

About Inverter's installation environment, please ensure it is in accordance with:

- (1) Environment temperature from -10°C to $+40^{\circ}\text{C}$
- (2) Environment humidity 0~95% without condensing
- (3) Away from direct sunlight
- (4) The environment does not contain corrosive gas and liquid
- (5) The environment does not contain dust, floating fiber, flock and metal dust.
- (6) Far away from radioactive materials and combustible substances
- (7) Far away from electromagnetic interference sources (as welder, high-powered machines)
- (8) The installation surface shall be firm. Without vibration, the vibration cannot be avoided, please add anti-vibration spacer to reduce vibration.
- (9) Please install Inverter in the location where it is good for ventilation,

inspection and maintenance, and in the incombustible substance of solid. Apart from heating unit (as break resistor).

(10) Preserve enough space for Inverter installation, especially for multiple Inverter installation. Please pay attention to the position of Inverter, and install an extra heat sink to keep environment temperature lower than 45°C.

A. Single Inverter installation

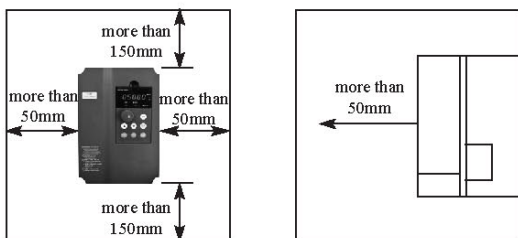

B. Multiple Inverters installed in one control cabinet.

Please pay attention: When installed "A", Inverter shall be placed in parallel

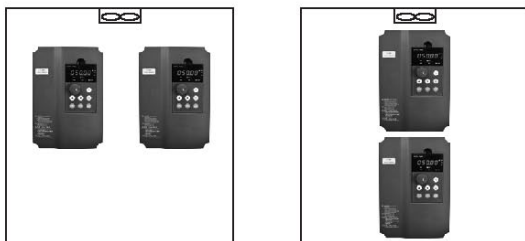

C. If multiple inverters are installed in one control cabinet. Please make sure that there is enough space, and mean while the air convection in the cabinet and the installation of heat sink.

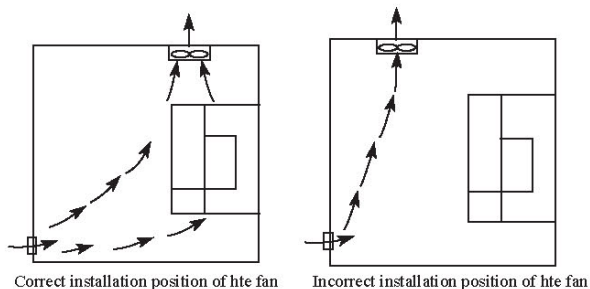

3-2 The outline and installation size

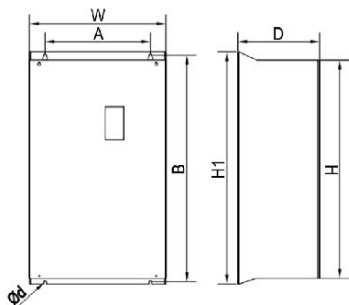

Unit: mm

Model	W	H	H1	D	A	B	d	Install	Casing
NZC0075T4B-Y	185	260	-	170	168	248	6.5	Wall Hang	Plastic
NZC0110T4B-Y									
NZC0150T4B-Y	210	330	-	190	195	310	6		Semi Plastic
NZC0180T4B-Y									
NZC0220T4B-Y									
NZC0300T4B-Y	277	410	-	189	262	390	5		Semi Plastic
NZC0370T4B-Y									
NZC0450T4B-Y	300	430	455	212	200	435	5		Iron Case
NZC0550T4B-Y									
NZC0750T4B-Y									

Model	W	H	H1	D	A	B	d	Install	Casing
NZC0900T4B-Y	380	625	650	252	250	625	9	Wall Hang	Iron Case
NZC1100T4B-Y									
NZC1320T4B(G)-Y									
NZC1600T4B(G)-Y	430	825	850	336	250	810	13		
NZC1850T4B(G)-Y									
NZC2000T4B(G)-Y	500	845	860	360	370	820	13		
NZC2200T4B(G)-Y									
NZC2000T4B(G)1-Y	530	800	860	335	200 +200	835	13	wall hang or floor installation	
NZC2200T4B(G)1-Y									
NZC2500T4B(G)-Y									
NZC2800T4B(G)-Y	620	1085	1100	380	460	1070	13		
NZC2800T4B(G)1-Y	620	850	910	335	250 +250	885	9		

3-3 The Hole size of the tray for the operating panel

141.5mm x 79.5mm

Chapter 4 Wiring

The wiring of Inverter can be divided into main loop and control loop.

4-1 Main loop wiring

4-1-1 External Components Description

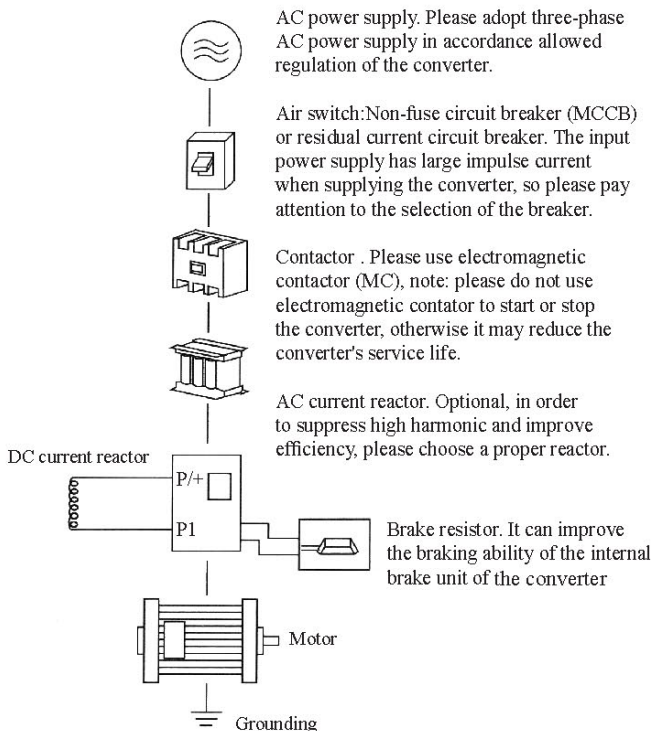

(1) AC power supply

Please supply power with the appointed power supply in the operational instruction.

(2) Non-fuse circuit breaker: (MCCB)

When the power supply voltage is low or short circuit of input terminal takes place, the breaker can provide protection, inspection and maintenance. Or Inverter does not run, you can cut off breaker to separate Inverters from the power supply.

(3) Electromagnetic contractor

The contractor can turn on and turn off power of Inverter to ensure safety.

(4) AC current reactor

A: suppress high harmonics for protecting Inverter.

B: improve the power efficiency.

(5) DC current reactor

The DC current reactor is as the same function as AC current reactor. Please remove the connection sheet first between P1 and P/+, shown as the following figures:

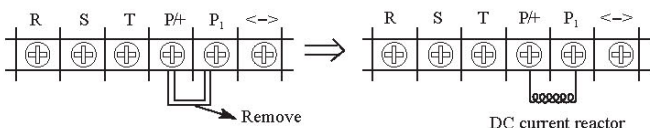

(6) Brake resistor

When the motor is braking, brake resistor can avoid DC loop high voltage of Inverter, and improve the braking ability of the internal brake unit.

Below 18.5W (including 18.5 W) the brake unit is built-in. The figure of the brake resistor connection is as below:

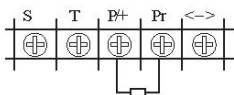

To select the brake resistor, please refer to section 2, chapter 9: Brake resistor configuration.

4-1-2 Main Loop Wiring Notice

- (1) Specifications of the circuit in wiring shall be in accordance with the regulations of electrical code.
- (2) Please do not connect the AC with the output terminal (u, v, w) of Inverter; otherwise it may cause Inverter damage.
- (3) Please use isolated cable and conduit, and connect with the two ends of the shielding layer or conduit with ground.
- (4) Grounding of Inverter shall not share with the welder, high-powered motor or high current load. Please connect with the ground independently.
- (5) Please adopt a third way to connect with the grounding terminal E \perp with the ground (impedance of the grounding is lower than 100Ω).
- (6) Please use the grounding cable according to the regulations of electric equipment technology. The shorter of the cable will be better.
- (7) If there is more than one Inverter connecting with the ground, please make sure that it does not form grounding loop, shown as the following figures:

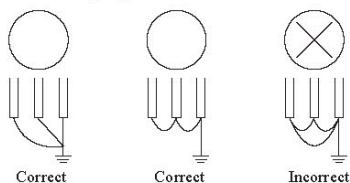

- (8) The main loop power cable and control cable must be laid separately. Keep minimum 10 cm distance in parallel, and vertical in intersection. Do not put the control cable and power cable in the same wire casing, otherwise it may cause interference.
- (9) The distance between Inverter and the motor shall be shorter

than 30 meters. If the distance is a long way, the impulse current which is produced by parasitical capacitance will lead to over current protection, or will produce wrong order may cause Inverter fault or running abnormality of the equipment. The maximum distance between Inverter and the motor shall not be over 100 meters. In the long-distance connection, please choose to configure filter in the output terminal, and meanwhile reduce carrier frequency.

(10) Do not add absorption capacitance or other capacitance-resistance absorbing devices in the output terminal (u, v, w) of Inverter.

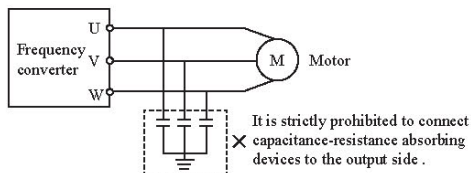

(11) Please confirm that the main loop terminal is locked firmly, and the lead wire and terminals have proper contact, to prevent looseness from vibration and creating spark leading.

(12) In order to reduce interference, the surge absorber is recommended to connect with the coil of electromagnetic contactor and relay in the surrounding circuit of Inverter.

4-1-3 Recommending Equipment Specifications

Model	Motor (KW)	Main circuit diameter (mm ²)	Breaker (A)	Contactor (A)
NZC0055T4B-Y	5.5	4	25	25
NZC0075T4B-Y	7.5	6	40	25
NZC0110T4B-Y	11	6	50	35
NZC0150T4B-Y	15	10	63	40

Model	Motor (KW)	Main circuit diameter (mm ²)	Breaker (A)	Contactor (A)
NZC0180T4B-Y	18.5	10	63	50
NZC0220T4B-Y	22	16	80	65
NZC0300T4B-Y	30	25	100	80
NZC0370T4B-Y	37	25	125	95
NZC0450T4B-Y	45	35	160	115
NZC0550T4B-Y	55	35	160	150
NZC0750T4B-Y	75	70	250	185
NZC0900T4B-Y	90	70	250	225
NZC1100T4B-Y	110	95	315	265
NZC1320T4B(G)-Y	132	150	350	330
NZC1600T4B(G)-Y	160	185	400	400

*The above data is only for reference.

4-1-4 Main loop terminals and description

If you open the outer casing of Inverter, you will see the main loop terminals.

1. Model P 3PH 380V 22KW or above:

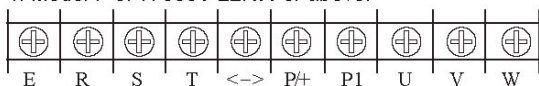

2. Model P 3PH 380V 15KW--18.5KW:



3. Model P 3PH 380V 5.5KW--11KW:

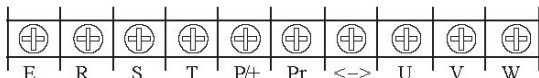

4-1-4-1 Main loop terminals and description

Name	Function description
E \perp	Grounding terminal
R, S, T	Power supply input terminal, one-phase 220V, select any two of the terminals to connect
P/+	DC voltage positive terminal
P1	Remove the connecting sheet between P1 and P/+ to connect with DC reactor.
Pr	The brake resistor can be connected between P1 and Pr (suitable for 15KW below models)
<->	DC voltage negative terminal, the brake unit can be connected between P1 and N/- (suitable for 18.5 KW above models)
U, V, W	Connect with three-phase AC motor

Cable connection examples:

1. Model P 3PH 380V 22KW or above:

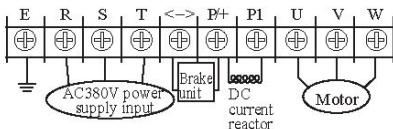

2. Model P 3PH 380V 15KW–18.5KW:

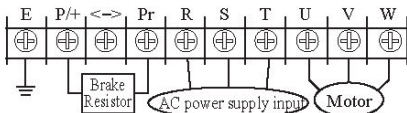

3. Model P 3PH 380V 5.5KW--11KW:

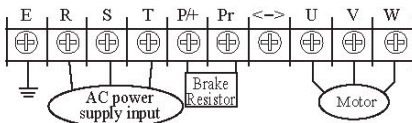

Note: The grounding terminal is on the casing next to the main loop terminal, and it is a screw hole on the steel plate marked with \perp ;

4. DC current reactor connection

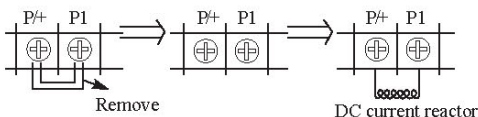

A. remove the short connecting sheet. B. connect DC reactor between P/+ and P1

5. Method of connecting with brake unit (apply to 22 KW above machines, including 22KW)

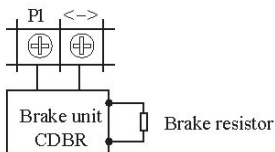

Due to different definitions of the brake unit terminal given by different producers, please refer to the relative instructions.

4-2 Control terminal

4-2-1 Basic wiring diagram

(1) Models below 18.5KW

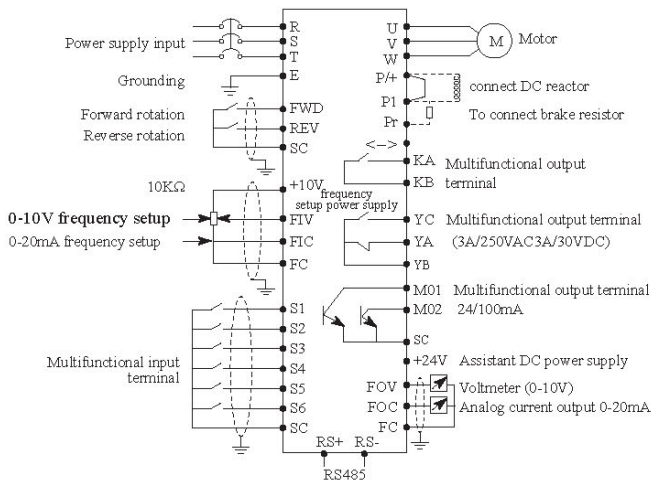

*Option of control board with dual-relay

(2) Model 22KW or above

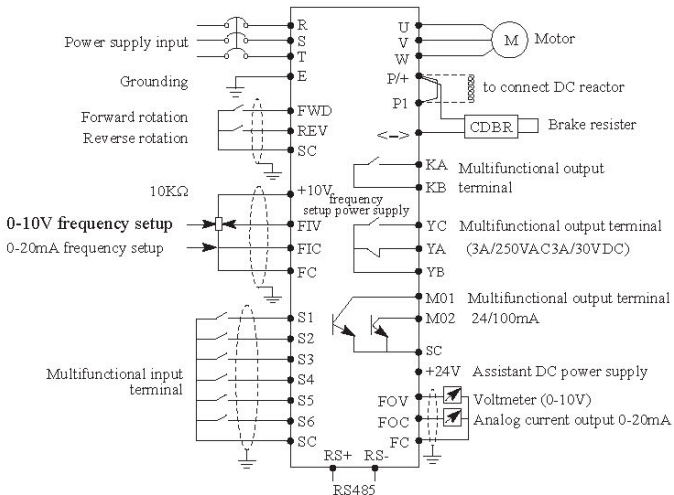

4-2-2 Control terminals arrangement

Model 5.5KW or above

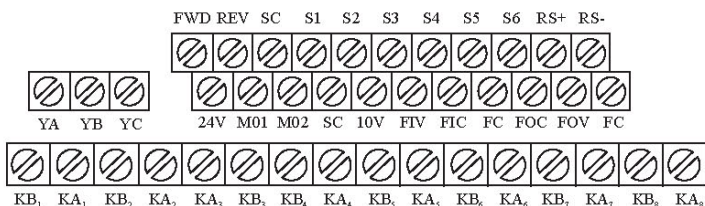

4-2-3 Control terminal description

Terminal name	Function description	Note
FWD	Forward rotation command input terminal (multifunctional input terminal)	Multifunctional input terminals S1-S6, FWD and REV can be set by parameters F3.15-F3.22 when the terminals and SC is closed.
REV	Reverse rotation command input terminal (multifunctional input terminal)	
S1	Multifunctional input terminal 1	
S2	Multifunctional input terminal 2	
S3	Multifunctional input terminal 3	
S4	Multifunctional input terminal 4	
S5	Multifunctional input terminal 5	
S6	Multifunctional input terminal 6	
24V	Assistant DC power supply, it supply 24V power for external devices	Max 100mA current
M01	Multifunctional output terminal (optical coupling)	Max 24V DC/100mA
M02	Multifunctional output terminal (optical coupling)	
+10V	Power supply for frequency setup	
FIV	Analog voltage command input terminal	0~10V (recommend using 10KΩ of potentiometer.)
FIC	Analog current command input terminal	0~20mA
FOV	Analog voltage output terminal	0~10V
FOC	Analog voltage output terminal	0~20mA

FC	Analog signal shared terminal	
SC	Digital signal shared terminal	
KA	Multifunctional output terminal	250V AC/3A, 30V DC/3A
KB	Multifunctional output terminal	
YC	Multifunctional output terminal (normally closed)	
YA	Multifunctional output terminal (normally closed)	
YB	Multifunctional YA, YB output contact mutual terminal	
RS+, RS-	RS485 communication port	
KA1,KB1- KA8,KB8	Contact Point of Motor A-G Industrial frequency\Convertible frequency	

4-2-4 Control Loop Wiring Notice





- (1) Please separate the control signal cable from the main loop cable, power cables and power supply cable.
- (2) In order to prevent interference that can cause false operation, please use glue shielding cable or two-ply shielding cable, whose specifications are 0.5-2mm².
- (3) Please confirm allowed requirements for using different terminals, requirements such as power supply, maximum allowed current
- (4) Please connect the grounding terminal E with the ground correctly. The grounding impedance is lower than 100Ω.
- (5) Please select accessories correctly according to the requirements as potentiometer, voltmeter and input current of different terminals.
- (6) Please check it correctly and confirm there is no mistake after wiring.

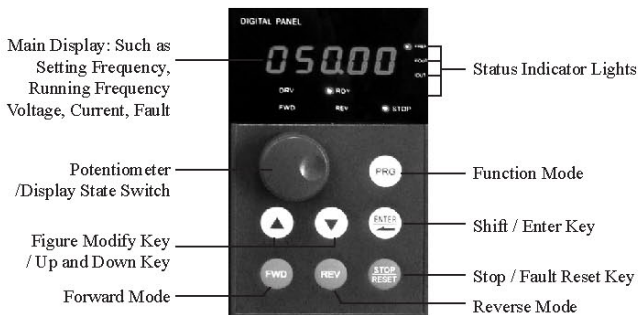

Chapter 5 Running

5-1 Digital Operating Panel



5-1-1 Key function description



Key name	Function description
	Function selection key, to select and use function menu
	Figures modification key, to modify function code and parameter
 	Shift key or Enter key Quick press to switch figures, press-and-hold to confirm setup
	① Potentiometer of operating panel, when the frequency is set up as controlled by potentiometer of operating panel, to rotate the potentiometer to get different frequency. ② Display switch, to press gently to display different monitor information



Key name	Function description
	Stop command key (apply to operating panel control state), fault reset key
	Forward rotation command key
	Reverse rotation command key

5-1-2 LED indicator light description

Indicator light name	Indicator light state	Description
DRV	Lighting	Inverter is on running state.
RDY	Lighting	Inverter is on standby state.
FREF	Lighting	Display area shows setup frequency.
FOUT	Lighting	Display area shows output frequency.
IOUT	Lighting	Display area shows output current.
FWD	Lighting	Inverter is in forward rotation state.
REV	Lighting	Inverter is in reverse rotation state.
STOP/RESET	Lighting	Inverter is in stop and no output state.





5-1-3 Display Description









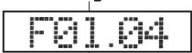

	Display	Description
1	FREF 	Display: Setup frequency 50.00Hz
2	IOUT 	Display: Output current 0.8A

	Display	Description
3	FOUT ● 	Display: Output frequency 0.5Hz
4		Display: Parameter F1.50
5	END	Display: Parameter setup is modified and confirmed successfully
6	OC 1	Display: Fault code, over current in acceleration

5-2 Operational Instruction of Digital Operating panel

(1) Parameter setup.(taking modifying F1.04 as example)

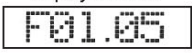







Program	Key name	Display	Description
1	Power on	RDY ● 	A. To display setup frequency picture (initial picture) B. Inverter is on standby state.
2	Press 	RDY ● 	To get into parameter setup state, and the first letter blinks (means modifiable item)
3	Press  4 times	RDY ● 	The value "0" has been changed to "4".







Program	Key name	Display	Description
4	Quickly press  twice (Quick press means shift.)	RDY ● 	The flashing is shifted 2 positions to the left. Note: Quick pressing means the pressing time is within 2 seconds.
5	Press  once	RDY ● 	The value "0" has been changed to "1".
6	Press and hold 	RDY ● 	Display: "1"
7	Press  	RDY ● 	Change "1" to "0"
8	Press and hold 	After flashing END, it displays F01.05 	Confirm that the value F1.04 has been modified
9	Press 	RDY ● 	Return to the original display picture

Notice: Press  to put away modification and directly return to the main picture state.

(2) Different state displays and inquiry

Assume that the parameter is set up: the operating panel controls Inverter to start and then stop (F1.02=0), and the frequency is given by the potentiometer of the operating panel (F1.01=3).

Program	Key name	Display	Description
1	Power on	RDY FREF 000.00	Setup frequency display state
2	Rotate 	RDY FREF 005.00	Setup frequency 5.0Hz
3		DRV FREF 005.00	Forward running of the frequency is on.
4	Press once 	DRV FOUT 005.00	Shift to actual running frequency display picture
5	Rotate 	DRV FOUT 015.00	Modify setup frequency, the actual running frequency has been changed from 5Hz to 15Hz
6	Press once 	DRV IOUT 010.00	Shift to output current display picture, the current output current is 10.00A
7	Press once 	DRV 020.00	Shift to output voltage state, the current output voltage is 20.00
8	Press twice 	DRV F00.00	Shift to parameter setup state
9	Press 	DRV F00.04	Select code F00.04 for modifying access parameter

Program	Key name	Display	Description
10	Press and hold 	DRV ● 	Display F00.04 which means the running rotation speed is 140
11	Press 	DRV FREF ● ● 	Return to main display picture, the setup frequency is 15Hz
12	Press 	RDY FREF ● ● 	Stop Inverter, the setup frequency is 15Hz

Notice: Through shift key, you can monitor setup frequency, running frequency, output current, and output voltage in running Inverter.

The display of the main picture can be customized by your actual need, and you can modify it by F0.00 setup. At the same time, you can monitor the content of relative display by F0.01-F0.18.

5-3 Simple Running and Relative Items

5-3-1 Setup, installation and wiring

According to detailed requirements to conduct installation and wiring

The figure is the simplest wire connection for the running as below:

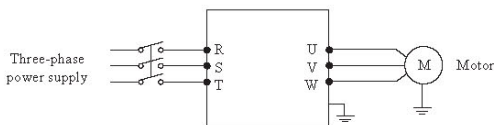

5-3-2 Wiring inspection

According to the wiring requirements of Inverter, check if there are errors. After confirming there is no mistake, turn on power supply to set up parameters.

5-3-3 Parameter setup

The basic parameter setup of running Inverter must have frequency setup and running signal source setup, in order that they can start Inverter on one hand, and indicate running speed of Inverter on the other hand.

Set up parameter F1.01 and F1.02 according to the requirements. About the setting-up method, please read chapter 5-2.

5-3-4 Running

Confirm that there is no mistake in wiring and parameter setup according to requirements

Assume F1.01=3 (the frequency source coming from the potentiometer of operating panel)

F1.02=0 (running signal source coming from the operating panel)

Press "FWD" to start Inverter, and then rotate the potentiometer, Inverter accelerates gradually.

Press "STOP" to stop Inverter

Notice: Observe state of the motor in running. If an abnormality takes place, please stop running immediately (to press STOP key) and turn off the power and check it.

Chapter 6 Table of Functional Parameters

**Setting F3.15~F3.22 for 27 to 30, F3.30~F3.33 and F20~F74 are only for P+ series

Code	Name	Description	Unit	Default
F0.00	The screen displays option setup	0-32	1	1
F0.01	Frequency setup	Read only		
F0.02	Output frequency	Read only		
F0.03	Output current	Read only		
F0.04	Rotation rate	Read only		
F0.05	Voltage of DC bus	Read only		
F0.06	Temperature of AC motor speed Controller	Read only		
F0.07	PID display	Read only		
F0.10	Fault record 1	Read only		
F0.11	Fault record 2	Read only		
F0.12	Fault record 3	Read only		
F0.13	Fault record 4	Read only		
F0.14	Setup frequency last fault	Read only		
F0.15	Setup frequency last fault	Read only		
F0.16	Setup frequency last fault	Read only		
F0.17	Setup frequency last fault	Read only		
F0.18	Setup frequency last fault	Read only		
F1.00	Setup of main frequency	0.00-upper limit frequency	0.01	0.00

Code	Name	Description	Unit	Default
F1.01	Option for frequency setup	0: digital frequency setup 1: Analog voltage setup 2: Analog current setup 3. Keyboard POT setup 4. UP/DOWN setup 5.RS485 communication frequency setup	1	0
F1.02	Option for running setup	0: Keyboard 1: IO terminal 2: Communication	1	0
F1.03	Setup when stop key is effective	0: Stop key is ineffective 1: Stop key is effective	1	1
F1.04	Setup for reverse	0: Reverse prohibited 1: Reverse allowed	1	1
F1.05	Maximum running frequency	Minimum running frequency ~ 400.00Hz	0.01	0.00
F1.06	Minimum running frequency	0.00 ~ maximum running frequency	0.01	0.00
F1.07	Acceleration time 1	0 ~ 6000.0S	0.1	Change
F1.08	Deceleration time 1	0 ~ 6000.0S	0.1	Change
F1.09	VF maximum voltage	VF intermediate voltage ~ 500.0V	0.1	400.0
F1.10	VF fundamental frequency	VF intermediate frequency ~ maximum running frequency	0.01	50.00
F1.11	VF intermediate voltage	VF minimum voltage ~ VG maximum voltage	0.1	Change
F1.12	VF intermediate frequency	VF minimum frequency ~ VF fundamental frequency	0.01	2.50
F1.13	VF minimum voltage	0~VF intermediate voltage	0.1	15.0
F1.14	VF minimum frequency	0~VF intermediate frequency	0.01	1.25
F1.15	Carrier frequency	1.0K-15.0K	0.1	Change
F1.16	Auto adjust carrier	Retain	1	0
F1.17	Initialization of parameters	8: Initialization of default	1	0
F1.18	Locked up of parameters	0: Unlocked of parameters 1: Locked up of parameters	1	0

Code	Name	Description	Unit	Default
F2.00	Option of start mode	0/1 regular start/re start after inspection	1	0
F2.01	Option for stop mode	0/1 ~ slow down/auto stop	1	0
F2.02	Setup of start frequency	0.10 ~ 10.00Hz	0.01	0.5
F2.03	Setup of stop frequency	0.10 ~ 10.00Hz	0.01	0.5
F2.04	Current for DC braking in start	0~150% pole rated current	1	100%
F2.05	Time for direct braking in start	0 ~ 25.0S	0.1	0
F2.06	Current of DC braking in stop	0~150% pole rated current	1	100%
F2.07	Time for DC braking in stop	0 ~ 25.0S	0.1	0
F2.08	Automatic torque compensation	0 ~ 20.0%	1	0
F2.09	Rated voltage of motor	0 ~ 500.0V	0.1	380.0
F2.10	Rated current of motor	0 setup current of system	0.1	Change
F2.11	No load current ratio of motor	0-100%	0.1	40%
F2.12	Rated rotation rate of motor	0-6000r/min	1	1420
F2.13	Number of poles	0-20	2	4
F2.14	Rated slip of motor	0~10.00Hz	0.01	2.50
F2.15	Rated frequency of motor	0-400.00Hz	0.01	50.00
F2.16	Resistance of stator	0-100ohm	0.01	0
F2.17	Resistance of rotor	0-100ohm	0.01	0
F2.18	Self inductance of rotor	0-1.000H	0.01	0
F2.19	Mutual inductance of rotor	0-1.000H	0.01	0
F2.20	Time for torque compensate filter	0~10.00S	0.01	0.10S
F3.00	FIV minimum voltage input	0~FIV maximum voltage	0.1	0
F3.01	FIV maximum voltage input	FIV minimum voltage~10V	0.1	10.0

Code	Name	Description	Unit	Default
F3.02	FIV input filter time	0~25.0S	0.1	1.0
F3.03	FIC minimum current input	0~FIC maximum current	0.1	0
F3.04	FIC maximum current input	FIC minimum current input~20mA	0.1	20.0
F3.05	FIC input filter time	0~25.0S	0.1	1.0
F3.06	FOV minimum voltage output	0~FOV maximum voltage	0.1	0
F3.07	FOV maximum voltage output	FOV maximum voltage output~10V	0.1	10.0
F3.08	FOC minimum current output	0~FOC maximum current	0.1	0
F3.09	FOC maximum current output	FOC minimum current~20mA	0.1	20.0
F3.10	Frequency of low analog	0~600.00	0.01	0.00
F3.11	Direction of low analog	0/1	1	0
F3.12	Frequency of high analog	0~600.00	0.01	50.00
F3.13	Direction of high analog	0/1	1	0
F3.14	Options for reverse of analog	0/1	1	0
F3.15	Input terminal FWD (0~32)	0: Ineffective 1: Jogging 2: Jogging forward 3: Jogging reverse 4: forward/reverse 5: Run 6: forward 7: Reverse 8: Stop 9: Multi-section terminal 1 10: Multi-section terminal 2 11: Multi-section terminal 3	1	6

Code	Name	Description	Unit	Default
F3.16	Input terminal REV (0~32)	12: Multi-section terminal 4 13: Acc/De terminal 1 14: 13: Acc/De terminal 2 15: Frequency increase signal 16: Frequency decrease signal 17: Emergency stop signal 18: Fault reset signal 19: PID in running 20: PLC in running	1	7
F3.17	Input terminal S1 (0~32)	21: Start signal for timer 1	1	1
F3.18	Input terminal S2 (0~32)	22: Start signal for timer 2 23: Counter pulse signal	1	18
F3.19	Input terminal S3 (0~32)	24: Counter reset signal 25: Memory clear	1	15
F3.20	Input terminal S4 (0~32)	26: Start winding movement	1	16
F3.21	Input terminal S5 (0~32)	*27: Stop 1 st pump *28: Stop 2 nd pump *29: Stop 3 rd pump	1	8
F3.22	Input terminal S6 (0~32)	*30: Stop 4 th pump	1	9
F3.23	Output terminal M01 (0~32)	0: Ineffective 1: In running 2: Frequency reached 3: Fault 4: Zero speed	1	01
F3.24	Output terminal M02 (0~32)	5: Frequency 1 reached 6: Frequency 2 reached 7: Acceleration 8: Deceleration 9: Indication for low voltage 10: Timer 1 reached 11: Timer 2 reached	1	02
F3.25	Alarm output terminal YA, YB, YC (0~32)	12: Phase completion 13: Procedure completion 14: PID upper limit 15: PID lower limit 16: 4-20mA disconnection 17: Detection of overload 18: Examination for over torque	1	03
F3.28	Alarm output terminal KA, KB (0~32) (*The board with KA, KB terminal only)	26: Completion of winding 27: Counter reached 28: Intermediate counter reached	1	0

Code	Name	Description	Unit	Default
F3.26	Output terminal FOV (0~32)	29: Water supply by constant voltage "1" effective "2" ineffective	1	0
F3.27	Output terminal FOC (0~7)	0: Frequency output 1: Current output 2: DC voltage 3: Ac voltage 4 pulse output, 1impulse/HZ 5.pulse output, 2impulse/HZ 6 pulse output, 3impulse/HZ 7.pulse output, 6impulse/HZ	1	1
F3.29	Terminal scan time	0.001~1.000S	0.001	0.02
F3.30	Open delay time less than maximum frequency at YA, YB, YC	0 ~ 6000	1S	10
F3.31	Close delay time more than maximum frequency at YA, YB, YC	0 ~ 6000	1S	10
F3.32	Open delay time less than minimum frequency at KA, KB	0 ~ 6000	1S	10
F3.33	Close delay time more than minimum frequency at KA, KB	0 ~ 6000	1S	10
F4.00	Jogging frequency setting	0.00~max fequency	0.01	5.00
F4.01	Acceleration time 2	0~6000.0S	0.1S	10.0
F4.02	Deceleration time 2	0~6000.0S	0.1S	10.0
F4.03	Acceleration time 3	0~6000.0S	0.1S	20.0
F4.04	Deceleration time 3	0~6000.0S	0.1S	20.0
F4.05	Acceleration time 4/jogging acceleration time	0~6000.0S	0.1S	2.0
F4.06	Deceleration time 4/jogging deceleration time	0~6000.0S	0.1S	2.0
F4.07	Designated value of counter	0~65000	1	100

Code	Name	Description	Unit	Default
F4.08	Intermediate value of counter	0~65000	1	50
F4.09	Limitation of acceleration torque	0~200%	1%	150%
F4.10	Limitation of constant speed torque	0~200%	1%	00
F4.11	Prevent over-voltage in deceleration	0/1	1	1
F4.12	Option for automatic voltage regulation	0~2	1	1
F4.13	Option for automatic energy saving	0~100%	1%	00
F4.14	Actuate voltage of brake-pipe	Change	0.1	Change
F4.15	Actuate ratio of brake-pipe	40~100%	1	50%
F4.16	Option for restart after power off	0~1	1	0
F4.17	Time for power off allowed	0~10S	1	5.0S
F4.18	Limitation of torque in racing start	0~200%	1	150%
F4.19	Time for racing start	0~25.0S	1	0.0
F4.20	Restart time in fault	0~5	1	0
F4.21	Restart time in fault	0~100.0S	2	2
F4.22	Option for actuating in over torque	0~3	1	0
F4.23	Horizontal detection of over torque	0~200%	1	00
F4.24	Time of detection of over torque	0~20.0S	0.1	00
F4.25	Reach frequency 1	0.00-upper limit frequency	0.01	48
F4.26	Reach frequency 2	0.00-upper limit frequency	0.01	30
F4.27	Setup timer 1	0~10.0S	0.1	0
F4.28	Setup timer 2	0~100.0S	1	0
F4.29	Time for torque of constant speed	0~6000.0S	0.1	Change

Code	Name	Description	Unit	Default
F4.30	Frequency reach width	0.00-2.00	0.01	0.50
F4.31	Jump frequency 1	0.00-upper frequency	0.01	0
F4.32	Jump frequency 2	0.00-upper frequency	0.01	0
F4.33	Jump frequency width	0.00-2.00	0.01	0.50
F4.34	Up/Down frequency step length	0~10.00Hz	0.01	0.1
F4.35	Up/Down frequency record	0:record 1:not record	1	0
F5.00	PLC memory mode	0~1	1	0
F5.01	PLC start mode	0~1	1	0
F5.02	PLC running mode	0: PLC stops after running in a cycle 1: PLC stop mode, it stops after running in a cycle 2: PLC circular running 3: PLC stop mode, circular running mode 4: PLC operates at the last frequency after running in a cycle.	1	0
F5.03	Multi-section speed terminal 1/Start frequency	0.00 ~ maximum running frequency	0.01	10.0
F5.04	Multi-section speed terminal 2/wind start frequency	0.00 ~ maximum running frequency	0.01	15.00
F5.05	Multi-section speed terminal 3/wind stop frequency	0.00 ~ maximum running frequency	0.01	20.00
F5.06	Multi-section speed terminal 4	0.00 ~ maximum running frequency	0.01	25.00
F5.07	Multi-section speed terminal 5	0.00 ~ maximum running frequency	0.01	30.00
F5.08	Multi-section speed terminal 6	0.00 ~ maximum running frequency	0.01	35.00
F5.09	Multi-section speed terminal 7	0.00 ~ maximum running frequency	0.01	40.00
F5.10	Multi-section speed terminal 8	0.00 ~ maximum running frequency	0.01	45.00

Code	Name	Description	Unit	Default
F5.11	Multi-section speed terminal 9	0.00 ~ maximum running frequency	0.01	50.00
F5.12	Multi-section speed terminal 10	0.00 ~ maximum running frequency	0.01	10.00
F5.13	Multi-section speed terminal 11	0.00 ~ maximum running frequency	0.01	10.00
F5.14	Multi-section speed terminal 12	0.00 ~ maximum running frequency	0.01	10.00
F5.15	Multi-section speed terminal 13	0.00 ~ maximum running frequency	0.01	10.00
F5.16	Multi-section speed terminal 14	0.00 ~ maximum running frequency	0.01	10.00
F5.17	Multi-section speed terminal 15	0.00 ~ maximum running frequency	0.01	10.00
F5.18	PLC running time 1/winding time	0~65000	1S	100
F5.19	PLC running time 2	0~65000	1S	100
F5.20	PLC running time 3	0~65000	1S	100
F5.21	PC running time 4	0~65000	1S	100
F5.22	PLC running time 5	0~65000	1S	100
F5.23	PLC running time 6	0~65000	1S	0
F5.24	PLC running time 7	0~65000	1S	0
F5.25	PLC running time 8	0~65000	1S	0
F5.26	PLC running time 9	0~65000	1S	0
F5.27	PLC running time 10	0~65000	1S	0
F5.28	PLC running time 11	0~65000	1S	0
F5.29	PLC running time 12	0~65000	1S	0
F5.30	PLC running time 13	0~65000	1S	0
F5.31	PLC running time 14	0~65000	1S	0
F5.32	PLC running time 15	0~65000	1S	0
F5.33	PLC running direction	0~32767	1	0
F5.34	Wind function	0: switch off 1:switch on	1	0

Code	Name	Description	Unit	Default
F6.00	PLD start mode	0: PID prohibited 1: PID open 2: Conditional running of PID. PID is open when external terminal is effective.	1	0
F6.01	PID running mode	0: Negative feedback mode of PID 1: Negative and positive feedback mode of PID	1	0
F6.02	Option for PID target value	0: Select figure as target value 1: Take FIV as target value 2: Pick up FIC as target value	1	0
F6.03	Option for PID feedback value	0: Take FIV as feedback value 1: Take FIC as feedback value 2: Take balance of FIV-FIC as feedback value 3. Take balance of FIC-FIV as feedback value	1	0
F6.04	PID figure target value	0.0~100.0%	0.1%	0.0%
F6.05	Upper limit value for PID alarm	0.0~100.0%	1%	100%
F6.06	Lower limit value for PID alarm	0.0~100.0%	1%	0%
F6.07	Value for P of PID	0.0~200.0%	0.1%	100%
F6.08	Value for I of PID	0.0~200.0S, 0 is closed	0.1s	0.1s
F6.09	Value for D of PID	0.00.0~20.00 S, 0 is closed	0.1s	0.0
F6.10	Step of each PID actuating	0.00~1.00Hz	0.01	0.10Hz
F6.11	PID sleep frequency	0.00~120.0Hz (0.00Hz) 0.00Hz means sleep function is closed	0.01	0.00Hz
F6.12	Time when PID sleep is active	0~200s	1S	10s
F6.13	Value for awoken PID from sleep	0~100%	1%	0
F6.14	Corresponding value of PID display	0~10000	1	1000

Operation Instruction of YMP Series Inverter

Code	Name	Description	Unit	Default
F6.15	Digital number PID display	1~5	1	1
F6.16	Digital number of decimal figure of PID display	0~4	1	1
F6.17	PID upper limit frequency	0~maximum running frequency	0.01	48.00
F6.18	PID lower limit frequency	0~maximum running frequency	0.01	20.00
F6.19	PID work mode	0: Always in work mode, when PID is open 1: When feedback reaches P6.05, it will work at minimum running frequency. When feedback reaches F6.06, PID will begin to work..	1	0
F6.20	Deviation limitation	0~10%	0.1%	1.0%
F6.20	KB1, KA1	0. Ineffective		2
F6.21	KB2, KA2	1.Contact Point of Motor A Industrial frequency		1
F6.22	KB3, KA3	2.Contact Point of Motor A Convertible frequency		4
F6.23	KB4, KA4	3.Contact Point of Motor B Industrial frequency		3
F6.24	KB5, KA5	4.Contact Point of Motor B Convertible frequency		6
F6.25	KB6, KA6	5.Contact Point of Motor C Industrial frequency		5
F6.26	KB7, KA7	6.Contact Point of Motor C Convertible frequency		8
F6.27	KB8, KA8	7.Contact Point of Motor D Industrial frequency 8.Contact Point of Motor D Convertible frequency 9.Contact Point of Motor E Industrial frequency 10.Contact Point of Motor E Convertible frequency 11.Contact Point of Motor F Industrial frequency 12.Contact Point of Motor F Convertible frequency 13.Contact Point of Motor G Industrial frequency 14.Contact Point of Motor G Convertible frequency		7

Code	Name	Description	Unit	Default
F6.28	Time second setting	0 ~ 60	1	0
F6.29	Time minute setting	0 ~ 60	1	0
F6.30	Time hour setting	0 ~ 24	1	0
F6.31	Time day setting	1 ~ 31	1	0
F6.32	Time month setting	1~ 12	1	0
F6.33	Time year setting	00 ~ 99	1	0
F6.34	A pump	0-3		1
F6.35	B pump	0-3		1
F6.36	C pump	0-3		1
F6.37	D pump	0-3		0
F6.38	E pump	0-3		0
F6.39	F pump	0-3		0
F6.40	G pump	0-3		0
F6.41	Pressure allowance of pump up	0 ~ 25.0%	0.1	5
F6.42	Running frequency of pump up	0 ~ max frequency	0.01	48
F6.43	Delay time of pump up	0 ~ 3600.0S	1	10
F6.44	Reserved			
F6.45	Pressure allowance of pump down	0 ~ 25.0%	0.1	5
F6.46	Running frequency of pump down	0 ~ max frequency	0.01	48
F6.47	Delay time of pump down	0 ~ 3600.0S	1	10
F6.48	Reserved			
F6.49	Time of injunction gate	0 ~ 10S	0.1	1
F6.50	Time of pull gate	0 ~ 10S	0.1	1
F6.51	Circuit time	0 ~ 65535 min	1	480
F6.52	Start time T1	00 ~ 23:59	0.1	0
F6.53	Start time T2	00 ~ 23:59	0.1	0
F6.54	Start time T3	00 ~ 23:59	0.1	0
F6.55	Start time T4	00 ~ 23:59	0.1	0
F6.56	Start time T5	00 ~ 23:59	0.1	0

Code	Name	Description	Unit	Default
F6.57	Start time T6	00 ~ 23:59	0.1	0
F6.58	Start time T7	00 ~ 23:59	0.1	0
F6.59	Start time T8	00 ~ 23:59	0.1	0
F6.60	Pressure 1	00 ~ 23:59	0.1	0
F6.61	Pressure 2	00 ~ 23:59	0.1	0
F6.62	Pressure 3	00 ~ 23:59	0.1	0
F6.63	Pressure 4	00 ~ 23:59	0.1	0
Code	Name	Description	Unit	Default
F6.64	Pressure 5	00 ~ 23:59	0.1	0
F6.65	Pressure 6	00 ~ 23:59	0.1	0
F6.66	Pressure 7	00 ~ 23:59	0.1	0
F6.67	Pressure 8	00 ~ 23:59	0.1	0
F6.68	Sleep section mode	0 ~ 255	1	1
F6.69	Sleep pressure allowance	0 ~ 25%	1	5
F6.70	Sleep continual time	0 ~ 3600.0S	0.1	30
F6.71	Sleep frequency	0 ~ max frequency	1	22
F6.73	Wake-up pressure allowance	0 ~ 25%	1	5
F6.74	Wake-up time	0 ~3600.0S	0.1	3
F7.00	Speed for communication	0: 4800 1: 9600 2: 19200 3: 38400	0	
F7.01	Communication mode	0: 8N1 FOR ASC 1: 8E1 FPR ASC 2: 8O1 FOR ASC 3: 8N1 FOR RTU 4: 8E1 FOR RTU 5: 8O1 FOR RTU	0	
F7.02	Local address of communication	0~240	1	0
F8.00	Superior applications	0: Locked 1: Unlocked	1	0
F8.01	Setup system	0:50Hz 1:60Hz	1	0
F8.02	Option of constant torque or changing torque	0: Constant torque 1: Changeable torque	1	0

Code	Name	Description	Unit	Default
F8.03	Setup of guaranteed level of over voltage	Change	1	Change
F8.04	Setup of guaranteed level of low voltage	Change	1	Change
F8.05	Setup of guaranteed level of over temperature	40~120°C	1	85/95°C
F8.06	Setup of displaying current filter time	0~10.0S	0.1	2.0
F8.07	0-10V analog output of low calibration coefficient	0-65535	1	-
F8.08	0-10V analog output of high calibration coefficient	0-65535	1	-
F8.09	0-20mA analog output of low calibration coefficient	0-65535	1	-
F8.10	0-20mA analog output of high calibration coefficient	0-65535	1	-
F8.11	Forward /Reverse operation compensation frequency point	0~maximum running frequency	0.01	0.00
F8.12	Up/Down frequency record	0: record 1: not record	1	0

Chapter 7

Detailed Explanations of Parameters

7-1 Parameters for Monitoring

F0.00	Display option setup default 00		
	Range 00-32	00	Display frequency setup
		01	Display frequency output
		02	Display current output
		03	Display rotation rate output/ PID target value
		04	Display main loop DC voltage
		05	Display temperature of module in Inverter
		06	Display of PID feedback

User can set the initial image of Inverter as the image which the user most desires through F0.00 setup so as to make monitoring more convenient.

For example, if the user wants to monitor rotation rate by main display image, the user can make the image display rotation rate by setting F0.00 as 03. The default of the parameter is 00. Therefore, it displays frequency setup directly when the power is on.

F0.01	Frequency setup
	Display the current frequency of Inverter.

You can monitor current frequency setup of Inverter by examining the content of the parameter.

F0.02	Output frequency
	Display the present output frequency of Inverter.

You can monitor present output frequency of Inverter by examining parameter F0.02.

F0.03	Current output
	Display the present output current of Inverter.

You can monitor present output current by examining parameter F0.03.

F0.04	Rotation rate
	Display the present rotation rate of motor.

You can monitor actual rotation rate of motor by examining parameter F0.04.

F0.05	Voltage of DC bus
	Display the voltage of DC bus in main loop of Inverter.

You can monitor present voltage of DC bus of main loop in Inverter by examining parameter F0.05.

F0.06	Temperature of Inverter
	Display the present temperature of Inverter module.

You can monitor present temperature of Inverter module by examining parameter F0.06, which will help you make a judgment on the running condition of Inverter.

F0.10	Error record 1
F0.11	Error record 2
F0.12	Error record 3
F0.13	Error record 4

	Record the latest four errors of Inverter.
--	--











You can check condition of latest four errors by examining F0.10 to F0.13. These four parameters can help user make a judgment on the running condition of Inverter and find the cause of production error and eliminate concealed trouble.

F0.14	The frequency at which the last error takes place
F0.15	The output frequency in last error
F0.16	The output current in last error
F0.17	The output voltage in last error
F0.18	The DC voltage in last error
	They display the detailed status of the latest error: You can check the actual setup frequency, actual output frequency, and DC voltage of main loop in Inverter by examining these parameters respectively.

You can check detailed state when the latest error takes place by examining the content of F0.14-F0.18. You can examine the setup frequency, actual output frequency, and actual output current and actual output voltage, DC voltage of main loop. According to the above data, you can analyze the cause of errors and find a solution quickly, which will help maintenance personnel in repairing work.

What more important is that for the Model A. P. H., you can use setup mode to choose main image freely and to monitor related content directly through F0.01-F0.08, but also you can examine related content by directly switching the operating panel.

When the operating panel is set for the following four conditions, you can check related content by pressing. "  " Take setup frequency as main image for example as below

Step	Press key	Display	Explanation
1	Turn on power	<p>RDY FREE</p> <p>• •</p> 	<p>A. Inverter is in standby mode.</p> <p>B. The main image is displaying setup frequency.</p> <p>C. the main image is displaying setup frequency when FREE light is on</p>
2	Press 	<p>DRV</p> <p>•</p> 	<p>Start Inverter</p> <p>A. Inverter is in running and DRV light is on.</p> <p>B. The image is displaying setup frequency.</p> <p>C. Inverter is in forward state when forward light is on.</p>
3	Press  once	<p>DRV FOUT</p> <p>• •</p> 	<p>Switch display image; switch to actual output frequency.</p> <p>A. Inverter is in forward state.</p> <p>B. The actual output frequency is 50.00Hz.</p> <p>C. FOUT light is on.</p>
4	Press  once	<p>DRV IOUT</p> <p>• •</p> 	<p>Switch display image; switch to actual output current.</p> <p>A. The actual current output is 2.5A</p> <p>B. The current image is displaying actual output current when IOT light is on.</p>
5	Press  once	<p>DRV</p> <p>•</p> 	<p>Switch display image; switch to actual output voltage.</p> <p>A. The current actual output voltage is 380V.</p>
6	Press  once	<p>DRV</p> <p>•</p> 	<p>Switch to main image</p> <p>A. Return to main image which will display setup frequency.</p> <p>B. The setup frequency is 50.00Hz</p>

7-2 Parameters for basic running

F1.00	Setup of dominant frequency			default: 0.00Hz
	Range	0.00-upper frequency	Unit	0.01

When F1.01 is set for 0, which is frequency setup option. When the setup mode is figure digital frequency, running frequency of Inverter is decided by F1.00.

In running, you can change frequency by modifying content of parameter F1.00 or by pressing upward key or downward key. If you change frequency by modifying F1.00, the modified content will be stored when Inverter stops running or power is off.

If you change frequency by pressing upward or downward key, the modified content will not be stored when Inverter stops running or power is off. Stored F1.00 will be worked when Inverter is started next time.

F1.01	Frequency setup option			default: 0
	Range	0-5	Unit	1
	Content	0: Digital frequency setup 1: Analog voltage setup 2: Analog current setup 3. Keyboard POT setup 4 UP/DOWN setup 5: RS485 communication setup		

Frequency setup option is used in selecting running frequency of Inverter.

0: Digital frequency setup

Running frequency of Inverter is decided by F1.00. You can change running frequency by pressing upward or downward key on operating panel. Refer to F1.00 in detail.

1: Analog voltage setup

Running frequency of Inverter is decided by external voltage signal (0-10V), put into Inverter through FIV terminal. There are two modes

of external voltage signal: one is designated signal ranging from 0 to 10V; the other is designated by POT. Refer to the following diagram for connection method.

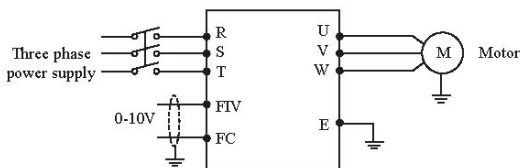

Explanation: control the running frequency of Inverter from 0 to 10V by FIV or FC

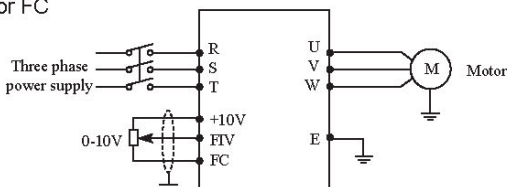

Explanation: control running frequency of Inverter been sent FIV voltage signal by external POT (10Kohm)

2: Analog current setup

The running frequency of Inverter is decided by external current signal (0-20mA). Control the running frequency of Inverter by external terminal FIC.

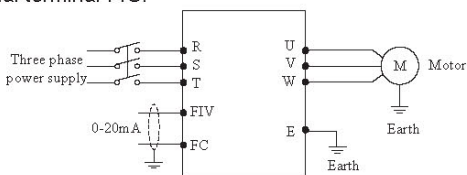

3: Keyboard POT setup

You can control running of Inverter by the POT knob on operating panel. That would be very convenient. Pay attention to the POT knob on operating panel with function of switching monitor images. Please be careful to use it.



Turn: change running frequency



Press: switch between monitoring images

4: UP/DOWN setup

The running frequency is controlled by external UP/DOWN terminal. External terminals can be selected from F3.15 to F3.22, been selected one of external terminals as UP/DOWN. When UP is Effective, the frequency will go up. When DOWN is effective, the frequency will go down. When both UP and DOWN are effective, the frequency will be the same.

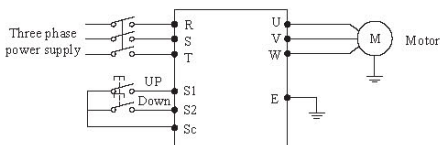

Parameter: F3.17=15, S1 terminal will be set in UP mode.

F3.18=16, S2 terminal will be set in DOWN mode.

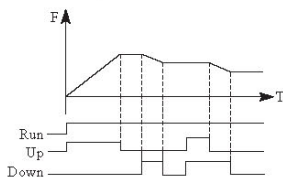

Explanation: When Up is effective (Up is connected), frequency will go up. When Down is effective (Down is connected), frequency will go down.

F1.02	Running setup option			default
	Range	0-2	Unit	1
	Content	0: Operating panel 1: IO terminal 2: RS485		

Running setup option is used in setting signal source.

0: Operating panel

Operating panel sends running signal. The running of Inverter can

be controlled by the FWD key (Forward) and REV (Reverse) key in operating panel of Inverter. Press stop key to stop running of Inverter.

Procedure	Press key	Display	Explanation
1	Turn on power	RDY ● 010.00	Presume the frequency is set at 10.0Hz
2	FWD	DRV ● 010.00	A. Inverter is in running mode. B. Inverter is in forward C. The running frequency is 10.00Hz
3	REV	DRV ● 010.00	A. Inverter is in reverse running mode. B. Switch between forward and reverse of Inverter C. The running frequency is 10.00Hz
4	STOP RESET	DRV ● 010.00	A. Inverter stops running B. Inverter is in standby mode.

1: IO terminal

IO terminal sends running command. You can setup external terminal at will. The default of FWD terminal is forward and the default of REV is reverse.

You can form two-wire-system or three-wire-system control mode by using IO terminal.

A. Two-wire-system mode

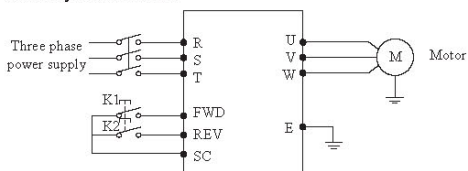

Parameter: F3.15=6

F3.16=7

Actuating explanation:

Shape and condition		Condition of Inverter
K1	K2	
ON	OFF	Forward
OFF	OFF	Stop
OFF	ON	Reverse
ON	ON	Keep running condition

B. Three-wire-system mode

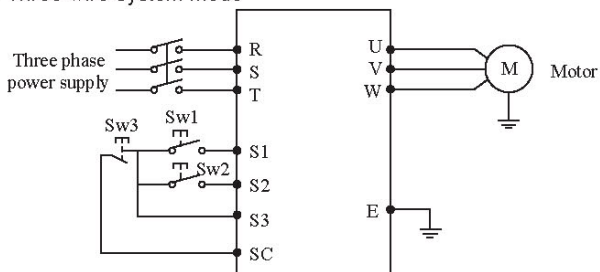

Use S1, S2, or S3 as input terminal for external signal

Parameter: F3.17=6 S1 is in forward

F3.18=7 S2 is in reverse

F3.19=9 S3 is in stop mode

F1.02=1 external terminal input

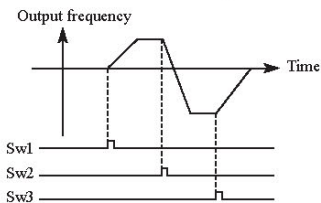

2: RS485

Serial interface sends running command to Inverter. Inverter will receive command from upper computer by serial interface.

F1.03	Setup of stop key			default 1
	Range	0-1	Unit	1
	Content	0: stop key is ineffective 1: stop key is effective		

When the running setup option is 1 or 2, equals the running command coming from external terminal or RS485, you can set stop key  on operating panel as ineffective or effective to prevent wrong running.

When F1.03 is set for 0, equals stop key is ineffective, stop key cannot stop running of Inverter.

When F1.03 is set for 1, equals stop key is effective, stop key can stop running of Inverter.

Attention: please dismiss running signal after you stop Inverter with pressing stop key. And restart Inverter then.

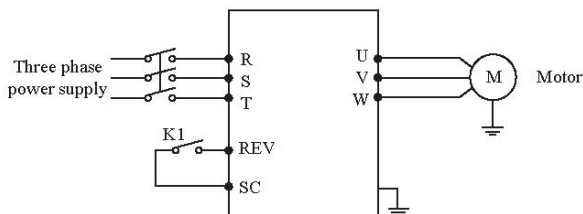

Procedure	Key and state	Explanation
1	K1 connected	Forward of Inverter starts
2	(K1 still connected) press stop key	Inverter stops
3	K1 disconnected	Running signal is removed
4	K1 connected	Forward of Inverter starts

F1.04	Setup of reverse	default 1		
	Range	0-1	Unit	1
	Content	0: Reverse prohibited 1: Reverse allowed		

Many machines only allow one single direction of rotation but not reverse; otherwise, mechanical fault or accident may take place. You can set machines in one single rotation mode by the parameter.

0: Reverse prohibited

Reverse of motor is prohibited. When F1.04 is set at reverse prohibited, switching between forward and reverse will be ineffective.

1: Reverse allowed

Motor allows reverse, switching between forward and reverse will be effective.

F1.05	Maximum running frequency	default 50.00		
	Range	Minimum running frequency □400.00Hz		

The running range of Inverter is between 0.1~400.00Hz. Therefore, Inverter tends to run high speed. Generally, motor and other machine run at 50Hz of the frequency. Over running may get mechanical fault or accident.

You can limit maximum running frequency of motor by the parameter preventing motor from high speed, wear of machine, and concealed trouble. You can set a maximum running frequency for Inverter according to actual need in production and techniques preventing wrong running.

F1.06	Minimum running frequency	default 0.00		
	Range	0.00□maximum running frequency		

Some machines and devices cannot be operated below a certain rotation speed in techniques. Especially, POT tends to get false

operation. You can put a limit to the minimum running frequency by the parameter. If the setup frequency signal is below that limit, Inverter will still output minimum frequency. Inverter operates at frequency between minimum running frequency and maximum running frequency, which can prevent false actuating and prevent overheat of motor caused by low running frequency.

F1.07	Acc time	default *
F1.08	DC time	default *
	Range	0.1~6000.0

ACC time is the time which reaches maximum running frequency from 0.00Hz in Inverter. DC time is the time which lowers minimum running frequency from maximum running frequency in Inverter.

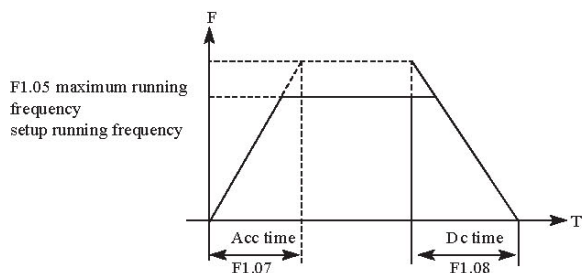

The default of acceleration/deceleration time of Inverter is the primary acceleration/deceleration time. If you need to use other acceleration or deceleration time, you will have to set by external terminal.

F1.09	V/F maximum voltage	default 400
	Range	V/F intermediate voltage~500.00 Minimum unit 0.01
F1.10	V/F fundamental frequency	default 50
	Range	V/F intermediate frequency ~ maximum running frequency Minimum unit 0.01

F1.11	V/F intermediate voltage		default *
	Range	V/F minimum voltage ~ V/F maximum voltage	Minimum unit 0.1
F1.12	V/F intermediate frequency		default 2.5
	Range	V/F minimum frequency ~ V/F fundamental frequency	Minimum unit 0.01
F1.13	V/F minimum voltage		default 15.0
	Range	0.0 ~ V/F intermediate voltage	Minimum unit 0.1
F1.14	V/F minimum frequency		default 1.25
	Range	0.0 ~ V/F intermediate frequency	Minimum unit 0.01

F1.09 to F1.14 of the parameters determine V/F curve of Inverter.
Set. V/F curve corresponds with different load.

Constant torque curve: apply to constant torque load, output voltage and output frequency in linear.

Down torque curve: apply to double torque load, like fan and pump.
Load which will increase as increasing of rotation rate is low in beginning.

High start torque curve: apply to heavy machine, whose load will quickly decrease to a certain value in beginning.

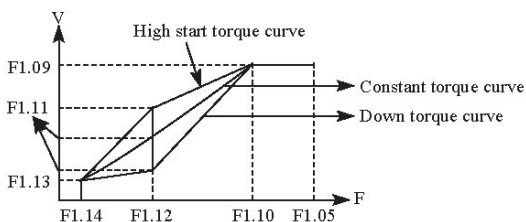

F1.09: Maximum V/F voltage.

Maximum V/F voltage which is set according to the parameter of motor brand will be at the rated voltage of motor in general. When motor is far away from Inverter, over 30m, it should be set for higher value.

F1.10: Standard V/F frequency

Please set according to the rated running voltage frequency of motor. Do not change standard V/F frequency setup. Otherwise, that may damage motor.

F1.11: intermediate V/F voltage

Set intermediate V/F voltage according to the specific load. Improper setup will cause over current of motor or insufficient output of torque, or even will cause protection of Inverter. Increasing the value of F1.11 will increase output torque. Meanwhile, output current will increase as well. Please monitor output current while changing the value of F1.11. The general requirement for setup is as the following: For start smoothly of Inverter, the current must be in the limit of Inverter in starting. Adjust up value of the parameter slowly until ideal value. Do not try to increase the value greatly. Otherwise, it may cause protection of Inverter or fault.

F1.12: intermediate V/F frequency

V/F intermediate frequency determines the intermediate point of V/F curve. Improper setup will cause insufficient torque or over current protection of Inverter. Do not change the setup value of the parameter in using.

F1.13: minimum V/F voltage

V/F minimum voltage setup is related to start torque. Increasing the value properly for the parameter may increase the torque of starting, and also cause over current. Generally, do not change the value of

F1.14: minimum V/F frequency

V/F minimum frequency determines the initial point of V/F curve, which is the minimum start value of Inverter.

Different loads have different V/F curves. According to the actual situation, adjust the V/F curve setup properly for Inverter. Refer to the following table for the specific default of each model of Inverter.

Parameter Model	F1.07	F1.08	F1.11	F1.15
NZC0055T4B-Y	15	15	23	7
NZC0075T4B-Y	18	18	22	6
NZC0110T4B-Y	20	20	22	5
NZC0150T4B-Y	22	22	20	5
NZC0180T4B-Y	28	28	20	4
NZC0220T4B-Y	30	30	19	4
NZC0300T4B-Y	35	35	18	4
NZC0370T4B-Y	38	38	18	4
NZC0450T4B-Y	40	40	17	4
NZC0550T4B-Y	45	45	17	3
NZC0750T4B-Y	50	50	16	3
NZC0900T4B-Y	60	60	16	2
NZC1100T4B-Y	80	80	15	2
NZC1320T4B(G)-Y	100	100	15	2
NZC1600T4B(G)-Y	120	120	14	1
NZC1850T4B(G)-Y	150	150	13	1
NZC2000T4B(G)-Y	200	200	12	1
NZC2200T4B(G)-Y	200	200	12	1
NZC2500T4B(G)-Y	220	220	12	1
NZC2800T4B(G)-Y	250	250	12	1

F1.15	Carrier frequency	default *
	Range	1-15 unit 1

Carrier frequency decides the switch frequency of power module in Inverter. Inverter with different frequency has different default because carrier frequency is affected by noise, heat effect and disturbance.

Carrier frequency F1.16	Noise	Heat rate	Effect on environment
Higher → Lower	Higher → Lower	Lower → Higher	Lower → Higher

Learning from the content of the above table, higher carrier frequency, lower noise, and higher heat rate will cause greater effect

on environment.

Therefore, when environment does not allow Inverter running with noise, you shall increase the value of F1.15. The maximum load of Inverter will decrease. For further occasion between motor and Inverter, you shall lower the value of F1.15 to decrease power leakage in wires and between wire and ground.

When the temperature of environment and load of motor are higher, you shall lower the value of F1.15 to improve the thermal property of Inverter. Refer to table in F1.14 for the default of F1.15.

F1.17	Initialization of parameters		default 0
	Range 0-8	Unit 1	
	Content	8: Initialization of parameters	

When improper parameter setup or wrong operation, you may set F1.17 for 08 to restore all parameters to the default, and then you can set them again according to actual need.

Attention: when locked parameters are effective, that is F1.18=1, you cannot carry out and change initialization of parameters. Please unlock first, and then set these parameters.

F1.18	Initialization of parameters		default 0
	Range 0-1	Unit 1	
	Content	0: Unlocked	1: Locked

You can lock up parameter by F1.18 to prevent unrelated personnel from improper changing and running.

When F1.18 is effective, that is parameters are locked. Parameters cannot be changed except this parameter and dominant frequency setup.

7-3 Parameters of basic applications

F2.00	Options of start mode			default 0
	Range	0-1	minimum unit	1
	Content	0: Start at start frequency 1: Racing start		

There are two start modes for Model A. P. H. You can select from F2.00 according to the condition of machinery.

0: Start at start frequency

Most loads do not need special requirement in start. In general, start the machine at start frequency that is the regular start mode.

1: Racing start

Racing start is suitable for restart in fault reset. In this situation, Inverter can automatically judge the rotation rate and direction of motor when you use racing start. And also start up the stopped motor directly according to the result of measurement and follow-up.

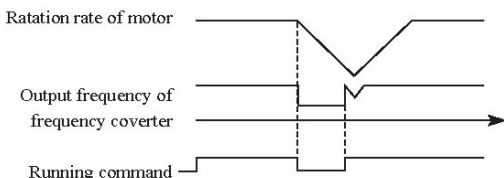

Attention: when Inverter starts in racing start mode, Inverter will keep track of the speed from high to low frequency. High current may be in start, and meeting over current is possible. Therefore, please notice over current level setup (4.09 setup) the specific value depends on the load.

Besides, when the value of 4.09 is set too low, it will start up follow-up slowly. In the follow-up process, if current surpasses follow-up level, Inverter will stop follow-up. Once the current is decrease down the level, Inverter will resume follow-up again.

F2.01	Options of stop mode			default 0
	Range	0-1	Unit	1
	Content	0: Decelerate to stop 1: Free running stop		

You can choose a suitable stop mode according to the actual load.

0: Deceleration stop

Once Inverter receives stop command, it will carry out deceleration according to the deceleration time and decrease output gradually until the output frequency reaches the frequency for stop.

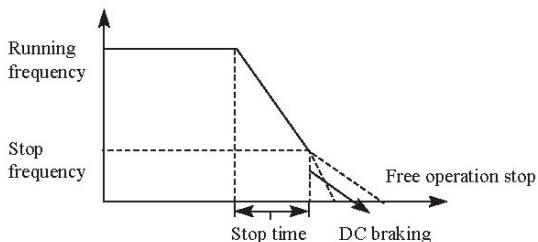

In stop mode after stop frequency is reached, you can choose DC braking and other options. If you do not choose DC braking, it will stop in free running stop mode.

1: Free running stop

When Inverter receives stop command, it will stop frequency output and it will have free running with load until it stops.

F2.02	Start frequency setup			default 0.5
	Range	0.10-10.00	Unit	0.01

Start frequency is the initial frequency when Inverter starts. For inertia, heavy load, and device which demands large torque, increasing start frequency can get them started easily. However, if the start frequency is set the value too high, it may cause over current protection.

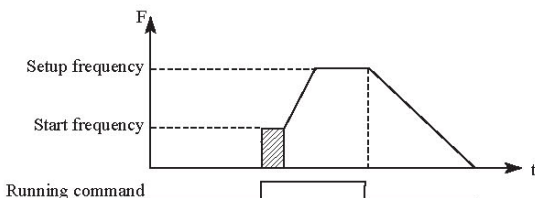

F2.03	Stop frequency setup			default 0.5
	Range	0.10-10.00	Unit	0.01

When Inverter receives stop command, it will begin to carry out deceleration and decrease output gradually according to the fixed time until reaching stop frequency. Then it will have free running stop or DC braking stop according to the setup.

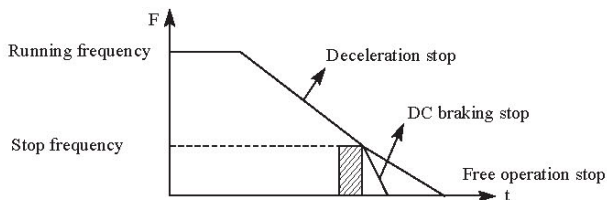

When DC braking is ineffective, Inverter decreases rotation rate until reaching stop frequency. Inverter will stop output by free running stop

F2.04	DC braking current in start			default 100
	Range	0-150	Unit	1
F2.05	DC braking time in start			default 0
	Range	0-250	Unit	1

DC braking in start is suitable for fan in stop mode and moving load. Before Inverter starts, motor is in free running mode and the rotation direction is not specified, AC motor will tend to get over current

protection in start. Therefore, you shall open DC braking to let load stay in stop mode before starting, and then start Inverter. This procedure can prevent over current protection.

DC braking current in start means that is the ratio of rated current of Inverter. Adjusting F2.04 will get different braking torque. While setting value of parameter, you can adjust it from low to high until reaching sufficient braking torque according to the actual load.

DC braking time is lasting. And when it is 0, DC braking is ineffective.

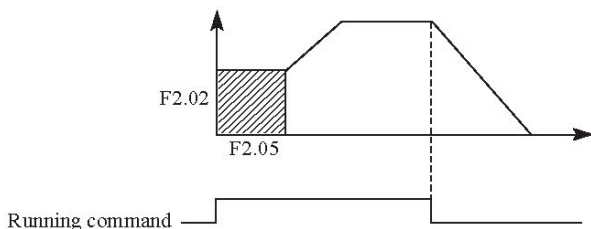

F2.06	DC braking current in stop			default 100
	Range	0-150	Unit	1
F2.07	DC braking time in stop			default 0
	Range	0-250	Unit	1

DC braking in stop is suitable for site which needs braking in strict requirement.

DC braking current in stop is the ratio of rated current of Inverter. Adjusting the parameter has different braking torque.

DC braking time is lasting. And when it is 0, DC braking is ineffective.

Refer to the explanations of F2.03, F2.04 and F2.05 for related details.

F2.08	Automatic torque compensation			default 5%
	Range	0.1-20%	Unit	0.1

Adjusting parameter F2.08 will increase voltage and obtain higher torque.

Attention: increasing torque by a great margin may make motor heated. Set proper increasing voltage according to the actual load.

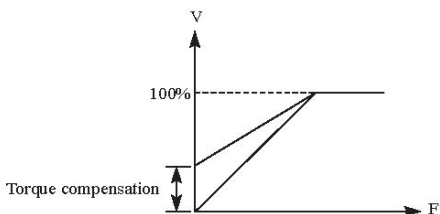

F2.09	Rated voltage of motor			default 380.00V
	Range	0-500.00V	Unit	0.01
F2.10	Rated current of motor			default *
	Range		Smallest unit	0.1
F2.11	Rated no load current of motor			default 40
	Range	0-100	Unit	1
F2.12	Rated rotation rate of motor			default 1420
	Range	0-6000	Unit	1
F2.13	Relative number of motor			default 4
	Range	0-10	Unit	1
F2.14	Rated slip of motor default 2.5			
	Range	0-100	Unit	0.1

The above parameter groups are the motor nameplate. Please follow the nameplate while setting parameters.

F2.09 rated voltage of motor

Please set rated voltage of motor according to voltage value on nameplate.

F2.10 rated current of motor

Please set rated current of motor according to the current value on the nameplate. If the running current exceeds the value of rated current, Inverter will activate protection to protection motor.

F2.11 rated no load current of motor

The value of no load current of motor would affect slip compensation. No load current is the percentage of motor current.

F2.12 rated rotation rate of motor

The value of parameter F1.12 is related to 50Hz of the rotation rate for displaying. Generally, it shall be set according to the value on the nameplate.

Display the actual rotation rate of motor. You can set parameter F2.12 for actual rotation rate at 50Hz.

F2.13 number of poles

Set the number of pole pairs of motor by adjusting this parameter according to the value on nameplate

F2.14 rated slip

When Inverter drives a motor, the more slip increase the more load increase. Adjusting F2.14 will set compensation rate and decrease slip and make motor approach simultaneous rotation rate.

F2.15	Rated frequency of Inverter default 50Hz			
	Range	0.00-400.00	Unit	0.01
F2.16	Resistance of stator default 0			
	Range	0-100.00	Unit	0.01
F2.17	Resistance of rotor default 0			
	Range	0-100.00	Unit	0.01
F2.18	Self inductance of rotor default 0			
	Range	0-1.000	Unit	0.001

F2.19	Mutual inductance of rotor			default 0
	Range	0-1.000	Unit	0.001

The above parameters are of motor.

F2.15 Rated frequency of motor

Please set rated frequency of motor according to motor nameplate.

F2.16 Resistance of stator

F2.17 Resistance of rotor

F2.18 Self inductance of rotor

F2.19 Mutual inductance of rotor

Set the above parameters according to the actual condition of motor.

7-4 Parameters for input and output application

F3.00	FIV minimum voltage input			default 0
	Range	0~FIV maximum voltage input	Unit	0.1
F3.01	FIV maximum voltage input			default 10.0
	Range	FIV minimum voltage input~110.0V	Unit	0.1
F3.02	FIV input filter time			default 1.0
	Range	0-25.0	Unit	1

F3.00 FIV minimum voltage input

FIV minimum voltage input value is related to frequency of low analog. Voltage signal below the value is as ineffective one.

F3.01 FIV maximum voltage input

FIV maximum voltage input value is related to frequency of high analog. For voltage higher than the value, the machine will still operate by value.

The value of F3.00 and F3.01 which are suitable for upper computer with different output deciding the range of input voltage. Due to disturbance and other reasons, error running is apt to take place with signal no more than 1V. Set F3.00 to avoid the signal below 1V for improving the anti-disturbance capacity.

F3.02 input filter time

Value of input filter time decides the analog response speed of Inverter. With the increasing value of F3.02, Inverter will get slower for responding of analog change.

F3.03	FIC minimum current input				default 0
	Range	0~FIC maximum current input	Unit	0.1	
F3.04	FIC maximum current input				default 20.0
	Range	FIC minimum current input-20.0mA	Unit	0.1	
F3.05	FIC input filter time				default 1.0
	Range	0-25.0 S	Unit	0.1	

F3.03: FIC minimum current input

FIC minimum current input is related to frequency of low analog. Inverter will take current signal below value of F3.03 as ineffective.

F3.04: FIC maximum current input

FIC maximum current input is related to frequency of high analog. For current command higher than value of F3.04, Inverter will operate by value.

F3.05: FIC input filter time

FIC input filter time decides how fast Inverter responds is in analog change. With the increase of value of F3.05, Inverter will respond more and more slowly in analog change. The output of Inverter will be relatively stable.

Refer to explanation of F3.00 to F3.02 for related parameters. If the external input is voltage signal, please refer to F3.00-F3.02. If the external input is current signal, please refer to F3.03-F3.05.

For example, if the output signal of upper computer is 4-20mA, the corresponding frequency shall be within the range of 0-50Hz.

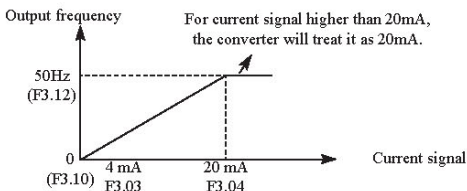

The Parameters: F3.03=4 F3.04=20 F3.10= 0 F3.12= 50

F3.06	FOV minimum voltage output			default 0
	Range	0-FOV maximum voltage output	Unit	0.1
F3.07	FOV maximum voltage output			default 10.0
	Range	FOV minimum voltage output-10.0V	Unit	0.1

The value of F3.06 and F3.07 decide the range of output voltage of FOV terminal.

F3.06: FOV minimum voltage output is related to frequency of low analog.

F3.07: FOV maximum voltage output is related to frequency of high analog. You can connect with voltmeters of various measurement ranges by setting parameter F3.06 and F3.07.

For example, use a frequency meter with input voltage of 0-5V and measurement range of 0-50Hz to monitor the output frequency of Inverter.

Then you need to set them like as following: F3.06-F3.07=5.

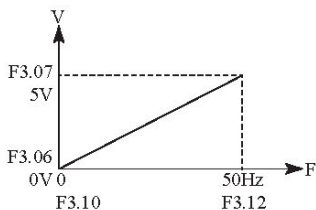

F3.08	FOC minimum current output				default 0
	Range	0-FOC maximum current output	Unit	0.1	
F3.09	FOC maximum current output				default 20.0
	Range	FOC minimum current output-20.0mA	Unit	0.1	

F3.08 and F3.09 decide the range of output current of FOC terminal. F3.08 and F3.09 correspond to frequency of low analog and frequency of high analog respectively. Refer to explanation of F3.06 and F3.07 for related parameters.

F3.10	Frequency of low analog				default 0.00
	Range	0.0-600.00 Hz	Unit	0.01	
F3.11	Direction of low analog				default 0
	Range	0-1	Unit	1	
	Content	0: Positive direction 1: Negative direction			
F3.12	Frequency of high analog				default 50
	Range	0.00-600.00Hz	Unit	0.01	
F3.13	Direction of high analog				default 0
	Range	0-1	Unit	1	
	Content	0: Positive direction 1: Negative direction			
F3.14	Analog reverse options				default 0
	Range	0-1	Unit	1	
	Content	0: No reverse at negative bias voltage 1: Reverse allowed at negative bias voltage			

The parameter groups of F3.10-F3.14 decide the running condition of analog, including running frequency and direction. According to actual need of user, they can form various control curves.

F3.10 frequency of low analog

Frequency of lower analog decides the running frequency of low analog, corresponding to analog minimum voltage (current) input.

F3.11 direction of lower analog

Direction of lower analog decides the running condition (forward or reverse) in low frequency.

F3.12 Analog high-end frequency

Analog high-end frequency determines high-end running frequency, and is corresponding to analog maximum voltage (current) input.

F3.13 Analog high-end direction

Analog high-end direction determines whether the running status of high-end frequency is forward or reverse.

F3.14 Analog reverse selection

Analog reverse selection determines running status of analog negative bias voltage, using above parameters can make up satisfied curve by customers.

Example 1: upper computer outputs 2-10 V signal to control Inverter, 50Hz reverse to 50Hz forward running.

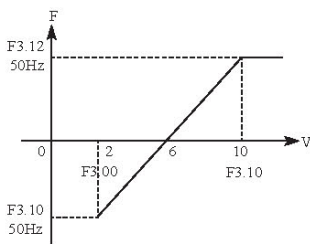

Introduction: F3.00=2 FIV minimum voltage input: 2V (Inverter regards signals below 2V as ineffective signals);

F3.01=10 FIV maximum voltage input: 10V (signals over 10V are regarded and handled as 10V);

F3.10=50 Analog low-end frequency: 50Hz;

F3.11=1 Analog low-end direction: 1 (reverse);

F3.12=50 Analog high-end frequency: 50Hz;

F3.13=0 Analog high-end direction: 0 (forward);

F3.14=1 Analog reverse option: 1 (negative bias voltage can be reversed).

Attention: In various curves, switching instructions of forward and reverse remains effective. When forward and reverse are switched, the curve will be reversed, and the diagram of curve is as follows:

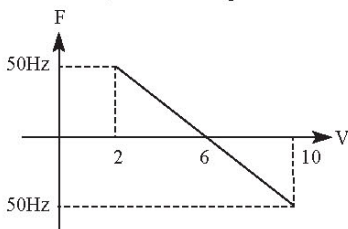

Example 2, upper computer outputs 4-20mA, and control running of Inverter

Running frequency is 100Hz-0Hz

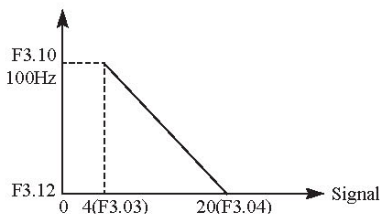

Parameter:

F3.3=4	FIC minimum current input
F3.04=20	FIC maximum current input
F3.10=100.00	Analog low-end frequency
F3.11=0	Analog low-end direction (forward)
F3.12=0	Analog high-end frequency
F3.14=0	Analog high-end direction (forward)

F3.10 ~ F3.14 can make up special inverted curve.

Introduction: signal input below 4mA is regarded as ineffective signal by Inverter.

F3.15	Multifunction input terminal---FWD terminal	Default 6
F3.16	Multifunction input terminal---REV terminal	Default 7
F3.17	Multifunction input terminal---S1 terminal	Default 1
F3.18	Multifunction input terminal---S2 terminal	Default 18
F3.19	Multifunction input terminal---S3 terminal	Default 15
F3.20	Multifunction input terminal---S4 terminal	Default 16
F3.21	Multifunction input terminal---S5 terminal	Default 8
F3.22	Multifunction input terminal---S6 terminal	Default 9
	Setup range	0-32
	Unit	1
	Content	0: Ineffective 1: Jog motion 2: Jog motion forward 3: Jog motion reverse
	Content	4: Forward/ reverse 5: Run 6: Forward 7: Reverse 8: Stop 9: Multi-speed selection one 10: Multi-speed selection two 11: Multi-speed selection three 12: Multi-speed selection four 13: Acceleration/ deceleration selection one 14: Acceleration/ deceleration selection two 15: Frequency increasing signal Up 16: Frequency decreasing signal Down 17: Free stopping 18: Fault reset 19: PID put into running 20: PLC put in 21: Timer 1 start up 22: Timer 2 start up 23: Counter pulse input 24: Counter reset 25: PLC memory removal 26: Winding action begins

0: Ineffective

Set as empty terminal, non-function

1: Jog

Set as jog, usually used in trial running, common jog is operated at 5Hz,

2: Jog forward

Set as jog forward

3: Jog reverse

Set as jog reverse

4: Forward/ reverse

Set as forward/ reverse switching. When the terminal is defined to

be effective, running status will reverse

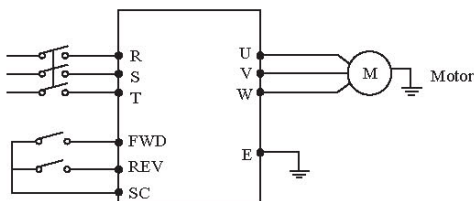

The parameters: F1.02=1, F3.15=6, F3.16=4

Terminal status		Running condition
FWD	REV	
ON	OFF	Forward
ON	ON	Reverse
OFF	OFF	Stop

5: Run

Set terminal as running signal.

6: Forward

Define terminal as forward. When the terminal is effective, Inverter will forward.

7: Reverse

Define terminal to be reversing, when terminal is defined as effective, Inverter reverses

8: Stopping

Define terminal to be stopping, when terminal is effective, Inverter decelerates and stops

9: Multi-speed one

10: Multi-speed two

11: Multi-speed three

12: Multi-speed four

15-speed can be integrated by multi-speed one, two, three and four.

The concrete speed is determined by status of multi-speed one, two, three and four.

Multi-function terminal				Status and Explanation
Multi-speed one	Multi-speed two	Multi-speed three	Multi-speed four	
0	0	0	0	Primary frequency, determined by F1.00 or potentiometer
1	0	0	0	Multi-speed terminal one (F5.03)
0	1	0	0	Multi-speed terminal two (F5.04)
1	1	0	0	Multi-speed terminal three (F5.05)
0	0	1	0	Multi-speed terminal four (F5.06)
1	0	1	0	Multi-speed terminal five (F5.07)
0	1	1	0	Multi-speed terminal six (F5.08)
1	1	1	0	Multi-speed terminal seven (F5.09)
0	0	0	1	Multi-speed terminal eight (F5.10)
1	0	0	1	Multi-speed terminal nine (F5.11)
0	1	0	1	Multi-speed terminal ten (F5.12)
0	0	1	1	Multi-speed terminal twelve (F5.14)
1	0	1	1	Multi-speed terminal thirteen (F5.15)
0	1	1	1	Multi-speed terminal fourteen (F5.16)
1	1	1	1	Multi-speed terminal fifteen (F5.17)

Remark: 0: ineffective terminal 1: effective terminal

13: acceleration/ deceleration option one

14: acceleration/ deceleration option two

Four kinds of acceleration/ deceleration time can be combined by acceleration/ deceleration selection one, two.

Multi-function terminal		Acceleration/ deceleration time and result
Acceleration/ deceleration option first	Acceleration/ deceleration option second	
0	0	One (F1.07, F1.08)
1	0	Two (F4.01, F4.02)
0	1	Three (F4.03, F4.04)
1	1	Four (F4.05, F4.06)

15. Frequency is increasing signal (Up signal)

When this terminal is effective, the frequency increases with even speed until operational frequency is the highest.

16. Frequency is decreasing signal (Down signal)

When this terminal is effective, the frequency decreases with even speed until operational frequency is the lowest.

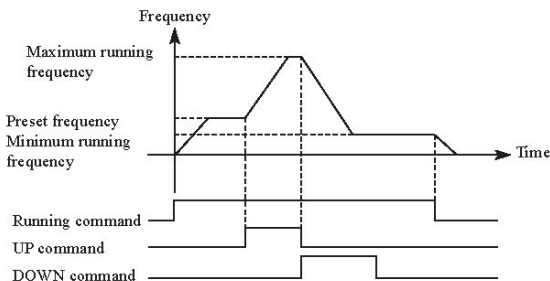

Attention: After Adjusting frequency with up/down, electric power is off, and reset again, adjusted frequency will not be stored. Inverter still stores value of F1.00.

17: Free stop

When terminal is effective, Inverter stops outputting and free stop.

18. Reset

When Inverter gets error, reset will restore the setting.

19. PID put into running

When this contact closes, PID will open. When F6.01 is set for 2, means PID condition is running, PID will be ineffective in contact point with disconnection.

20. PLC put into running

When this contact closes, PLC function starts up, and corresponding PLC function opens.

21. Timer 1 starts up

22. Timer 2 starts up

When this contact closes, timer starts up and begins counting, when the timer reaches set value, corresponding multifunction outputs contacting action.

23. Counter pulse input

This terminal may accept pulse signals no more than 250 Hz.

24. Counter resetting

The counted values may be reset and cleared through this terminal.

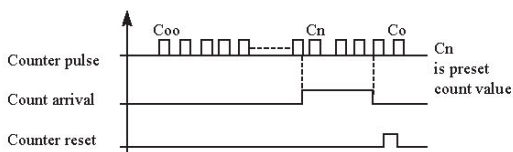

25. PLC memory removal

In the running process of PLC program, due to fault or stop, Inverter will record status of the program automatically after the fault is cured and Inverter is switched on again, Inverter will continue running according to the program, when memory removal is effective, program may be reset, and Inverter operates from the beginning.

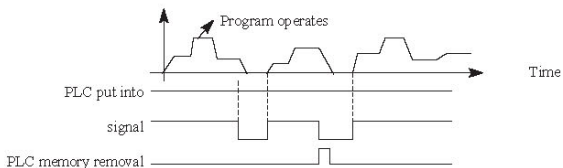

26. Winding action begins

When this contact is activated, winding begins.

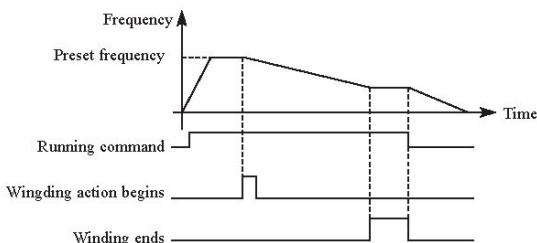

- Introduction: A. Detonating winding before winding action begins;
 B. When winding ends, Inverter will output
 C. When Inverter stops, winding ends of multi-terminal output will reset automatically.

F3.23	Output terminal M01	default 01		
F3.24	Output terminal M02	default 02		
F3.25	Alarm Output terminal YA, YB, YC	default 03		
F3.28	Alarm Output terminal KA, KB	default 00		
	Range	0-32	Unit	1
	Content	0: Ineffective 1: In running 2: Fault arrival 3: In fault 4: Zero-speed 5: Frequency 1 arrival 6: Frequency 2 arrival 7: Accelerate 8: Decelerate 9: Low-voltage alarm 10: Timer 1 arrival 11: Timer 2 arrival 12: Stage completion indication 13: Process completion indication 14: PID upper limit 15: PID lower limit 16: 4-20mA disconnection 17: Overload detection 18: Over torque detection 26: Winding ends 27: Set counter arrival 28: Middle counter arrival		

0: Ineffective

Set as empty terminal, prevent false running.

1: In running

Terminal is set in running, when Inverter output or command, the terminal will take action.

2: Frequency arrival

When frequency arrives at preset value, this contact will take action.

3: In fault

When Inverter detects abnormal point, the contact will take action.

The contact can be alarming.

4: Zero-speed

When frequency output is less than start frequency, the contact will take action.

5: Frequency 1 arrival

6: frequency 2 arrival

When frequency arrives at preset value, the contact will take action.

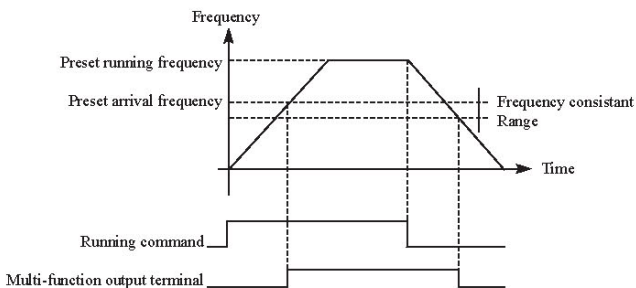

7: Acceleration

When Inverter is in acceleration, the contact will take action.

8: Deceleration

When Inverter is in deceleration, the contact will take action.

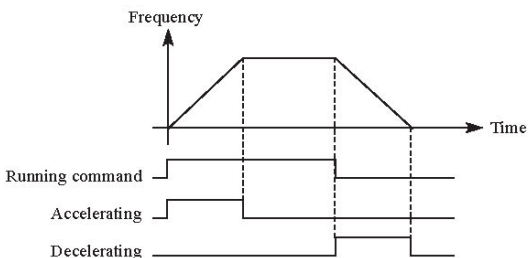

9. Low-voltage alarm

When Inverter detects that DC bus is lower than preset value, this contact will take action and alarm, low-voltage alarming preset value can be set through advanced application parameter group.

10: Timer 1 arrival

11: Timer 2 arrival

When Inverter arrives at preset value, the contact will take action. When timer start signal is removed, the contact will reset.

12: Stage completion indication

When program of Inverter is running, multi-function output contact will output a pulse in every finished stage.

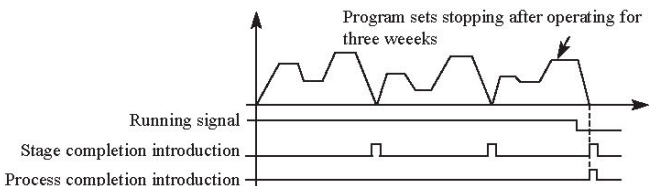

13. Process completion indication

When all procedure of Inverter completed, the pulse can be alarming signal to notify operational personnel, or can be start signal in next procedure.

14. PID upper limit

When PID feedback quantity exceeds preset value of upper limit, this contact will take action, it is usually taken by alarming output, or emergent stopping to prevent accidents.

15: PID lower limit

When PID feedback quantity is lower than preset value, the contact will take action.

16: 4-20mA disconnection

When FIC input signal is disconnected, the contact will take action and alarm.

17: Overload detection

When Inverter detects the motor with overload, the contact will take action.

18: Over torque detection

When Inverter detects over torque, the contact will take action.

26: Winding ends

When winding action ends, the contact will take action. When Inverter stops, winding ends and contact will reset.

27: Set counter arrival

When running external counter in Inverter, the contact will take action in the value arriving at preset value (F4.25).

28: Middle counter arrival

When Inverter is counting, the contact will take action in the value (F4.26).

F3.26	Output terminal FOV			default 0
	Setup range	0-7	Minimum unit	1
F3.27	Output terminal FOC			default 1
	Content	0: Output frequency 1: Output current 2: Direct voltage 3: Across voltage	4: pulse output, 1pulse/HZ 5: pulse output, 6: pulse output, 7: pulse output,	

F3.26 output terminal FOV

FOV terminal can output 0-10V voltage through F3.06 and F3.07 corresponded to output frequency, output current, direct voltage, across voltage.

F3.27 output terminal FOC

FOC terminal can output 0-20m current through F3.08 and F3.09 corresponded to output frequency, output current, direct voltage, alternating voltage.

0: Output frequency:

Current (voltage) output is corresponded to minimum running frequency -----maximum running frequency.

1: Output current

Current (voltage) output is corresponded to 0—2×rated current of Inverter.

2: Direct voltage

Current (voltage) output is corresponded to 0—1000V.

3: Across voltage

Current (voltage) output is corresponded to 0—510V.

4. Pulse output, corresponding with running frequency: 1pulse/HZ (50%)

5. Pulse output, corresponding with running frequency: 2pulse/HZ (50%)

6. Pulse output, corresponding with running frequency: 3pulse/HZ (50%)

7. Pulse output, corresponding with running frequency: 6pulse/HZ (50%)

For example: select a frequency meter of 0-5V, monitor output frequency, set the minimum running frequency of Inverter as 0.00Hz, and the highest running frequency is 80Hz.

Then:

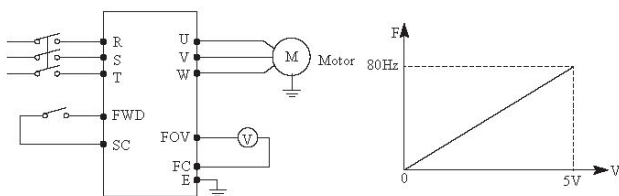

The parameter: F1.05=80.00 maximum running frequency

F1.06=0.00 minimum running frequency

F3.06=0.00 FOV minimum voltage output

F3.07=5.00 FOV maximum voltage output

7-5 Auxiliary application group

F4.00	Jog frequency setting			default 5.00
	Setup range	0.00—maximum running frequency	Unit	0.01

Jog frequency setting is suitable for test running. Jog function can run only by external terminal selected at will.

When jog function is running, other instruction cannot be accepted.

Inverter will decelerate and stop off running jog. Acceleration/ deceleration of Jog accept Acceleration/ Deceleration time 4.

Prior level in Control:

Jog → External multi-speed → PLC running mode → PID mode → Triangular wave running mode → winding → setup mode.

Several control modes input and operate at same time by the highest prior level.

F4.01	Acceleration time 2			default 10.0
F4.02	Deceleration time 2			default 10.0
F4.03	Acceleration time 3			default 20.0
F4.04	Deceleration time 3			default 20.0
F4.05	Acceleration time 4			default 2.0
F4.06	Deceleration time 4			default 2.0
	Setup range	0-6000.0	Minimum unit	0.1

Inverter preset four acceleration/ deceleration time. In general, Inverter only accepts the first acceleration/ deceleration time. Jog accepts the fourth acceleration/ deceleration time. User may select acceleration/ deceleration time at will by requirement. In external multi-speed, external terminal decides acceleration/ deceleration time. In internal multi-speed, different acceleration/ deceleration time may be selected by simple PLC.

F4.07	Designated value of counter			default 100
F4.08	Middle value of counter			default 50

	Setup range	0-6500	unit	1
--	-------------	--------	------	---

2 groups of counter in Inverter can accept pulse signal less than 250Hz through multi-function terminal. When the value reaches presetting in counter, corresponding multi-function output terminal will take action, and input terminal of counter will reset signal through the counter, witch will recounting again. Pulse signal may use proximity switch and photoelectric switch to be input signals.

F4.09	Accelerating torque limiting level		default 150	
	Setup range	0-200	Unit	1

In the acceleration of Inverter, output current of Inverter may be higher than the protection range. Limiting level of overage current may be set by F4.09. When electric current reaches set value, Inverter will stop accelerating. Not until the under set value, Inverter continues accelerating

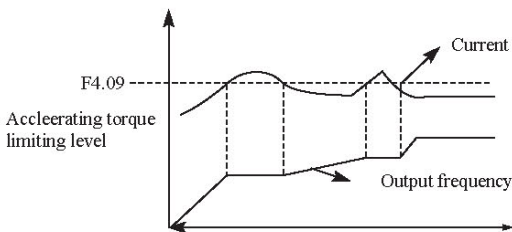

100% current is the rated current of Inverter. When F4.09 is set for 0, then acceleration torque limit is ineffective, without protection.

F4.10	Constant-speed torque limiting level		default 00	
	Range	0-200	Unit	1

In the constant-speed running of Inverter, Inverter will be without protection in over current. With non-limitation, constant-speed torque limiting level can be set by F4.10. When the current exceeds set value of F4.10, Inverter will auto reduce output frequency. Not

until coming back normal level, Inverter accelerates to set frequency (100% current is rated current of Inverter).

When F4.10 is set for 0, constant-speed torque limited level is ineffective and cannot be protected.

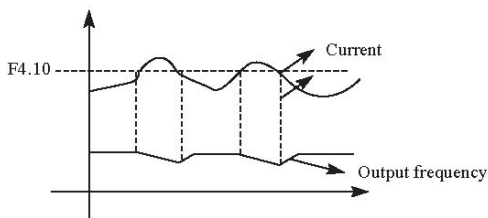

F4.11	Over-voltage prevention in deceleration		default 1
	Range	0-1	Unit
	Content	0:Ineffective 1:Effective	

In the decelerating process of Inverter, rapid deceleration may increase the DC-bus voltage of Inverter. When Over-voltage prevention in deceleration is ineffective, Inverter will meet over-voltage protection if non-measure.

1: Effective

Over-voltage prevention in deceleration is effective. When voltage reaches set value, Inverter stops decelerating first in the stopping process of Inverter. Not until DC-bus voltage returns to permissible value, Inverter continues decelerating.

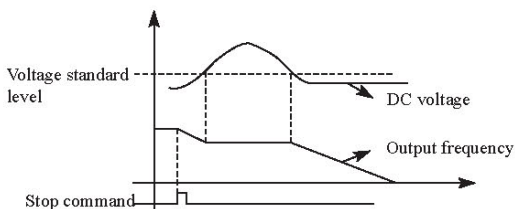

F4.12	Automatic voltage stabilizer			default 1
	Range	0-2	Unit	1
	Content	0: Ineffective 1: Effective 2: Ineffective in deceleration		

When motor runs under the condition of instable input electric, temperature will increase, insulation will be damaged, and output torque will be instable in motor

0: Ineffective

Choose ineffective of automatic voltage stabilizer, Inverter output voltage will fluctuate.

1: Effective.

Choose effective of automatic voltage stabilizer, voltage of Inverter output will be stable automatically in condition of instable input electric.

2: Ineffective in deceleration: this function will enhance braking function of AC motor speed.

F4.13	Automatic stored energy			default 0.0
	Range	0-100	Minimum unit	1
F4.14	Brake-pipe action voltage			default 80
	Range	P*: 650.0V~800.0V P*: 360.0V~400.0V	Unit	0.1
F4.15	Brake-pipe action ratio			default 50
	Range	40-100	Unit	1

F4.13 Automatic stored energy

In constant-speed running of automatic stored energy, the best voltage value which provided to load may be calculated by loading condition in order to saving energy.

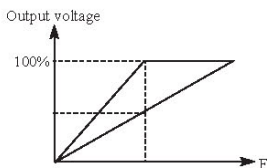

Attention: When load changes frequently or almost full load, this function will not be suitable.

F4.14 and F4.15 are only for built-in braking unit in Inverter, not for external braking unit.

The two parameters above set internal DC high voltage standard level and ratio of braking action of Inverter.

F.4.14 Brake-pipe action voltage

When DC high voltage is higher than set value of F4.14, built-in braking unit will take action. Energy would release and DC voltage would come back by braking resistance. Built-in braking unit closes until DC voltage falls to a certain value

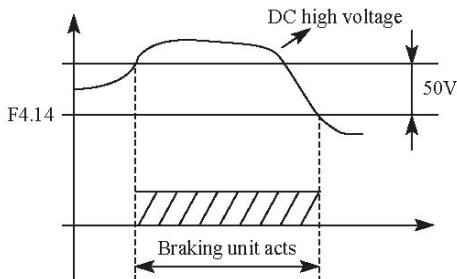

Please pay attention to setting the parameter. DC voltage may be over to cause protection in high value of this parameter. Braking resistance may be heated in low value.

F4.15 Ratio of brake-pipe action

Ratio of brake-pipe action is suitable for braking unit. Using average voltage value of braking resistance will adjust pulse-duration modulation. Duty ratio is equal to ratio of braking action, almost equal to ratio of switching tube. The bigger the ratio the quicker energy releases and the more power consumes on resistance.

F4.16	Restart after instant power off		default 0	
	Setup range	0-1	Unit	1
	Content	0: Ineffective: no restart after instant power off 1: Effective: frequency tracking start		

0: Ineffective

In ineffectively, Inverter auto removes running commands after power is off. It would start regularly on recovery power

1: Effective

In effectivity, Inverter will keep commanding in a period time (in allowable time of power cut) after power is off. Inverter starts by frequency tracking start in power on. Inverter will auto remove running commands over a period time. It would start regularly on recovery power

Attention: when “restart after instant power off” works, Inverter will suddenly start up. Please pay attention to safety. Besides, when a terminal control start and stop of Inverter, external terminal condition must be paid attention to. In power cut, external terminal is still closed, so Inverter will suddenly start when power is on. Please be careful.

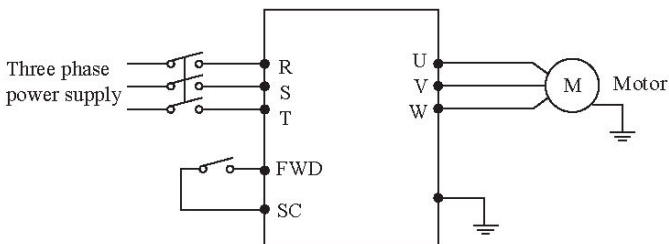

For example: Use K1, control running.

K1 is closed, K1 will be cut off in running, and Inverter will stop then. K1 remains closed in power cut. When power is on, Inverter starts up suddenly. It is very dangerous. Please use other controlling methods such as three-wire system connection method.

F4.17	Allowable time of power cut			default 5.0
	Setup range	0-10.0	Minimum unit	0.1

F4.17 in setting allowable time of power cut, if time of power cut is over set value, "restart after instant power off" will be ineffective.

F4.18	flank restart current limited level			default 150
	Range	0-200	Minimum unit	1

When Inverter drives flank restart, Inverter will track downward from set frequency immediately. Output current of Inverter will increase more rapidly up to exceed protection unit. Meanwhile, Inverter would stop tracking, and output current of Inverter would come back to common. Inverter will continue tracking. Value 100% of this parameter is rated current of Inverter. The protection of Inverter in track may be set by F4.18.

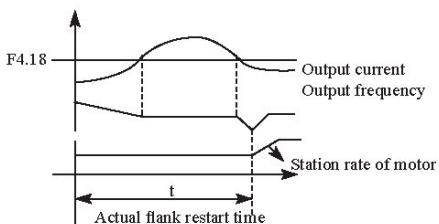

F4.19	Flank restart time			default 5
	Range	0-10	Unit	

When Inverter drives flank restart, Inverter will track downward from set frequency immediately. Complete tracking in setup range of time. If it does not finished in setup time, Inverter will be protected. In illustration of F4.18, when $t > F4.19$ setup value, Inverter will be protected.

F4.20	Restart frequency with error			default 0
	Range	0-5	Unit	1

F4.21	Restart time with error			default 2
	Range	0-100	Unit	1

After abnormality (such as over current, over-voltage) takes place, Inverter will auto reset (effectively in non-zero of F4.20). After the period time set by F4.21, Inverter will start up according to presetting start mode (F2.00).

After start, if no abnormality happens in 60 seconds, Inverter will auto reset F4.20.

If abnormality happens again within 60 seconds, Inverter will record number of times. Once reaching set value of F4.20. Inverter will stop outputting, not to auto reset or restart again.

Attention: when the number of restart times in error is set for zero, restart in error will be ineffective. When restart in error is effective, Inverter will suddenly restart. It is very dangerous to use this function. Please be careful.

F4.22	Over torque action			default 0
	Range	0-3	Minimum unit	1
	Content	0: Frequency arrives. Inverter begins detecting over torque. Inverter continues running 1: Frequency arrives. Inverter begins detecting over torque. Inverter stops running 2: In running, Inverter detects over torque, Inverter continues running 3: In running, Inverter detects over torque, Inverter stops running		

Introduction: 0: when running frequency reaches set frequency, Inverter will begin detecting over torque. When detection of Inverter reaches over torque, Inverter will continue running, and detect over torque in acceleration.

1: When running frequency reaches set frequency, Inverter will begin detecting over torque. When Inverter detects over torque, Inverter will stop.

2: Inverter begins to detect over torque on running. When over torque

is detected, Inverter will not handle it and continue running.

3: Inverter begins to detect over torque on running. When over torque is detected, Inverter will stop.

F4.23	Over torque detection level			default 0
	Range	0-200	Minimum Unit	1
F4.24	Over torque detection time			default 0
	Range	0-200	Minimum Unit	1

When output current of Inverter exceeds set value of F4.23 (over torque detection level), Inverter will figure out torque time.

When the duration exceeds half of set value of F4.24 (over torque detection time), corresponding multi-function terminal will take action, over torque will alarm, and frequency conversion will continue running. If the duration exceeds set value of F4.24, Inverter will be protected and be taken action by F4.22. When over torque detection level is set for zero, over torque detection will be ineffective, and 100% is Inverter rated current.

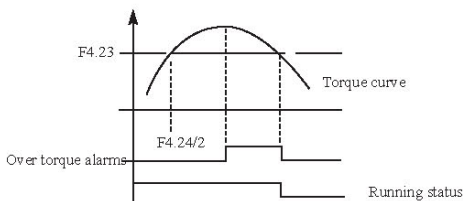

F4.25	Reaching frequency one			default 48
	Range	0-Maximum running frequency	Minimum unit	0.1
F4.26	Reaching frequency two			default 30
	Range	0-maximum preset frequency	Unit	0.1

Set two groups of reaching frequency. When running frequency arrives at set value of F4.25 and F4.26, corresponding multi-function output terminal will take action. Width of arrival of frequency is a hysteresis loop set by F4.30.

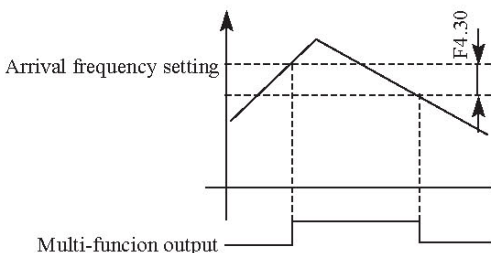

F4.27	No. 1 timer			default 0
	Range	0.0-6000.0S	Minimum unit	0.1
F4.28	No. 2 timer			default 0
	Range	0.0-6000.0S	Minimum unit	0.1

When two timers which are common one reaches set value (set by F4.27 and F4.28), corresponding multi-function terminal will take action. The timers are started by external multi-function input terminal.

Some of simple program actions may be made with two timers.

F4.29	Constant-speed torque limiting time			default 0.50
	Range	0-6000.0S	unit	0.1
F4.30	Width of arrival of frequency in hysteretic loop			default 0.50
	Range	0.00-2.00	unit	0.01

This parameter sets frequency arrival width. For details, please refer to F4.25-F426 introductions.

F4.31	Jump frequency one			default 0
	Range	0.00-frequency upper limit	unit	0.01
F4.32	Jump frequency two			default 0
	Range	0.00-frequency upper limit	unit	0.01
F4.33	Jump frequency hysteretic loop width			default 0.50
	Range	0.00-2.00	unit	0.01

Due to machinery reason and other reasons, in running of Inverter, there is a certain frequency caused resonance. For avoiding

resonance point, resonance frequency may be overlapped through F4.31-F4.33 to achieve the purpose of avoiding resonance. Set two jump frequencies totally. To provide convenience for customer, jump broad width can be set at will by F4.33 as follows:

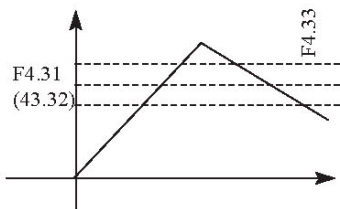

F4.34	Terminal UP/DOWN frequency range			default 0.1Hz
	Range	0-6000.0S	unit	0.1Hz
F4.35	UP/DOWN frequency memory selection default 0			
	Range	0.00-2.00	unit	0.01
	Content	0: stored 1: not stored		

Control UP/DOWN to raise and low down the speed. When the terminal is effective, to increase or decrease set frequency F3.34 every 40ms. The selection of UP/DOWN frequency memory, please refer to F8.12 function.

7-6 Application function group

F5.00	PLC store mode			default 0
	Range	0-1	Unit	1
	Content	1: Stored 0: Non-stored		

Pause of program running function can be run by F5.00 to achieve saving program running.

0: Non-stored

In the operational process of PLC program, F5.00 will choose not to store. When machinery stops because of error or other reasons,

Inverter will not store status before the stopping. After restarting, running status will begin from initial state.

1: Stored

In the running of PLC program, F5.00 will choose to store. When it stops because of error or other reasons, Inverter will store status before running. After restarting, Inverter will continue running.

Attention: power cannot be cut off.

Stop, power cut and power on, Inverter will not store status before power cut. After restarting, Inverter will run according to initial state of program.

F5.01	PLC start mode			default 0
	Range	0-1	Minimum unit	1
	Content	0: Ineffective (PLC does not start) 1: Effective (PLC starts)		

F5.01: option for running mode of Inverter:

F5.01=0, PLC will not start, Inverter will run in common mode.

When F5.01=1, PLC will start, Inverter select programs to run.

Under the status of PLC start, when there are various running orders and programs, Inverter will choose the highest level to run according to priority level.

Precedence level	Priority level	Item
High→ low	1	Jog
	2	External multi-speed
	3	Internal multi-speed
	4	PID
	5	Triangular wave
	6	Winding
	7	Setting mode

F5.02	PLC running mode			default 0
	Range	0-4	Unit	1

	Content	0: PLC stops after running for a week 1: PLC pause mode, stops after running for a week 2: PLC cycle running 3: Cycle running of PLC pause mode 4: After running for a week, PLC continues running by the end of running frequency
--	---------	--

PLC running mode decides running status of internal multi-speed, either running one circle or cycle running. F5.02 is only effective when PLC starts up.

PLC pause mode means that when completing every speed in the running process of internal multi-speed, the speed will be down, stop, and accelerate to the next speed. The illustration is as below:

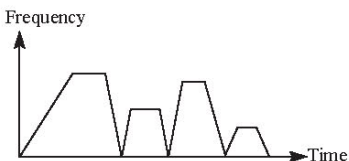

User may select proper running mode according to actual conditions.

F5.03	Multi speed terminal 1	default 10.0
F5.04	Multi speed terminal 2	default 15.0
F5.05	Multi speed terminal 3	default 20.0
F5.06	Multi speed terminal 4	default 25.0
F5.07	Multi speed terminal 5	default 30.0
F5.08	Multi speed terminal 6	default 35.0
F5.09	Multi speed terminal 7	default 40.0
F5.10	Multi speed terminal 8	default 45.0
F5.11	Multi speed terminal 9	default 50.0
F5.12	Multi speed terminal 10	default 10.0
F5.13	Multi speed terminal 11	default 10.0
F5.14	Multi speed terminal 12	default 10.0
F5.15	Multi speed terminal 13	default 10.0
F5.16	Multi speed terminal 14	default 10.0

F5.17	Multi speed terminal 15	default 10.0		
	Range	0.00----Maximum running frequency	Unit	0.01

F5.03 ---- F5.17 is set of 15 speed of rated frequency in the running. Regarding relationship Multi speed and external terminal please refer to rated instruction 1, 2, 3, 4 of multifunctional end.

F5.18	PLC running period 1	default 100		
F5.19	PLC running period 2	default 100		
F5.20	PLC running period 3	default 100		
F5.21	PLC running period 4	default 100		
F5.22	PLC running period 5	default 100		
F5.23	PLC running period 6	default 0		
F5.24	PLC running period 7	default 0		
F5.25	PLC running period 8	default 0		
F5.26	PLC running period 9	default 0		
F5.27	PLC running period 10	default 0		
F5.28	PLC running period 11	default 0		
F5.29	PLC running period 12	default 0		
F5.30	PLC running period 13	default 0		
F5.31	PLC running period 14	default 0		
F5.32	PLC running period 15	default 0		
	Range	0 ----- 65000	Unit	1

PLC running period decides duration of internal multi speed in every part of speed. The running duration in every part is corresponding to its rate.

F5.33	PLC running duration 15	default 0		
	Range	0 ---- 32767	Unit	1

F5.33 set running direction of every part

Method of setting running direction:

The way of running direction is 16-bit binary system, and then transfer to decimal system value. Every bit decides the corresponding running direction: 0 is forward and 1 is reverse. This

parameter will be only effective when the PLC is on.

For example: there is a five-part rate, the circling running is required as follow:

Items	Running frequency	Running direction	Running period
Dominant frequency	Adjustable potentiometer	Forward	
Part 1	20.0	Reverse	20
Part 2	60.0	Forward	25
Part 3	40.0	Reverse	30
Part 4	15.0	Forward	20

Two buttons, one of which is for running, the other one is for stop. The main frequency must be with adjustable potentiometer.

(1) Connection illustration

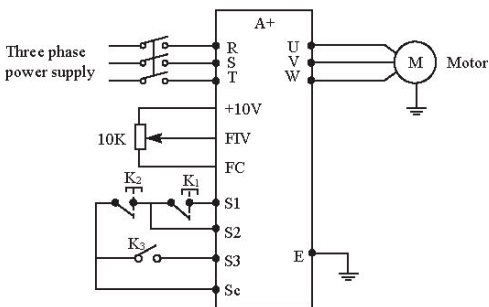

(2) The parameter setting

Setting of PLC running direction: (F5.33 setting)

Rate of part 4	Rate of part 3	Rate of part 2	Rate of part 1	Dominant frequency
4	3	2	1	0
0	1	0	1	0
0×2^4	1×2^3	0×2^2	1×2^1	0×2^0

→ position (bit)

→ changing direction <0 is forward, 1 is reverse>

→ change into decimal system

The binary system number 01010 is changed into decimal system number:

$$1 \times 2^1 + 1 \times 2^3 + 8 = 10$$

F5.33= 10

The parameter defines to:

F1.01=3 (Keyboard potentiometer setting mode: dominant frequency is

controlled by potentiometer)

F1.02=1 (Running setting option: multifunctional terminal input)

F1.05=60 (The maximum running frequency is 60HZ)

F1.07=10 F1.08= 10 (acceleration/deceleration 10S)

F3.17=6 (S1 terminal as forward)

F3.18=8 (S2 terminal as stop)

F3.19=20 S3 terminal is that PLC start to run

F5.00=1 PLC programming memory

F5.01=1 PLC is on

F5.02=0 PLC running a circle and then stop

F5.03=20 Part1 is set for 20Hz

F5.04=60 Part1 is set for 60Hz

F5.05=40 Part1 is set for 40Hz

F5.06=15 Part1 is set for 15Hz

F5.18=10 Part1 is set for running duration 10s

F5.19=20 Part1 is set for running duration 20s

F5.20=25 Part1 is set for running duration 25s

F5.21=30 Part1 is set for running duration 30s

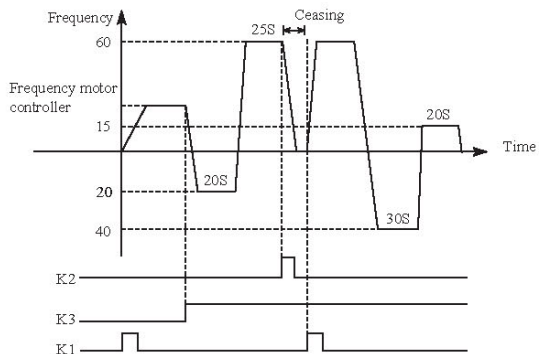

Instruction:

- Press K1 to start running with the frequency by potentiometer.
- Press K3 to start PLC running from first part by program until run a circle, and the stop.
- If the program is running, press K 3. If there is an error, stop Inverter, then the error is removed, press K1 then Inverter will run by program.
- If F5.00 is set for 1 and the program is not stored, running will start from very beginning.

Triangle wave function: The function for textile and printing field to make traverse function.

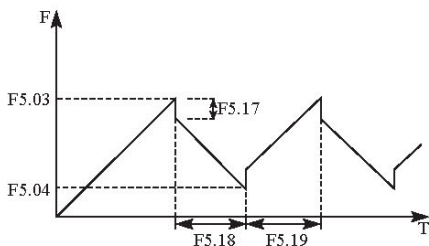

Instruction:

- The frequency of every turning point: decide by F5.03、 F5.04

2. The jump frequency is decided by F5.17.
3. Running time is decided by F5.18、F5.19.
4. F5.35=1start this function.

7-7 Auxiliary application group (PID)

F6.00	PID start mode			default 0
	Range	0-1	Unit	1
	Content	0: Ineffective PID off 2: PID works on terms 1: Effective PID on		

0: Ineffective: PID function will not work.

1: Effective: PID will work without external input terminal.

2: PID work on terms: PID will work, with external terminal PID input operating is effective status, will turn on PID and start working function.

F6.01	PID mode			default 0
	Range	0-1	Unit	1
	Content	0: Ineffective negative feedback mode 1: Effective positive feedback mode		

0: Negative feedback mode

If feedback value is bigger than target value, when set F6.01 = 0 to choose negative feedback mode, the controller will decelerate speed. If feedback value is smaller than target value, then it will accelerate speed.

1: Positive feedback mode

Positive feedback mode is contrary to negative feedback mode. If feedback value is bigger than target value, when set F6.01 = 1 to choose positive feedback mode, the controller will accelerate speed. If feedback value is smaller than target value, then it will decelerate speed.

F6.02	PID target value			default: 0
	Range	0-2	Unit	1

	Content	0: Select numeric target value 1: Choose FIV as target value 2: Choose FIC as target value
--	---------	--

F6.02 is set the source of target value, model A. P. H. can choose three ways. Target value can set by Inverter, external terminal, voltage, current input, and etc.

0: Select numeric target value.

Target value is to be given by F6.04.

1: Choose FIV as target value.

Target value is given by voltage signal or potentiometer through FIV.

2: Choose FIC as target value.

Target value is given by current signal through FIC.

F6.03	PID target value selection			default: 0
	Range	0-2	Unit	1
	Content	0: Choose FIV as feedback value 1: Choose FIC as feedback value 2: Choose the difference between FIV and FIC as feedback value 3: Choose the difference between FIC and FIV as feedback value		

Notes: F6.03 parameter setting: Select PID feedback channel

0: Choose FIV as feedback value

Feedback would be voltage signal

1: Choose FIC as feedback value

Feedback would be current signal

2: Choose the difference between FIV and FIC as feedback value

Choose FOV and FOC as feedback channel

3: Choose the difference between FIC and FIV as feedback value

Choose FIC and FIV as feedback channel

F6.04	PID numeric target value			default: 0.0
	Range	0.0-100%	Unit	0.01
	Content	0: Choose FIV as feedback value		

Numerical target value is completely corresponding to analog +10V voltage.

PID closed-loop control is used in the process of physical quantity with dull change such as control of pressure, temperature.

Feedback signal is given from temperature transmitter, pressure transmitter. In case of PID control, the channel of feedback signal input is of analog current signal 4 – 20mA or 0 – 10V. There are two channels available for setting.

PID closed-loop control is effective in multi-functional input of PID. The diagram of PID control:

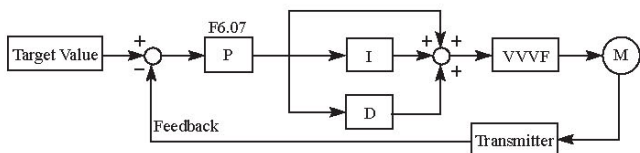

General regulation method for PID control:

- (1) Select proper transmitter, whose input specification shall be 4 – 20mA or 0 – 10V.
- (2) Set proper target value.
- (3) Increase proportionality constant (P), in case of non-oscillating output;
- (4) Decrease integration time (Ti), in case of non-oscillating output;
- (5) Increase derivative (Td), in case of non-oscillating output;

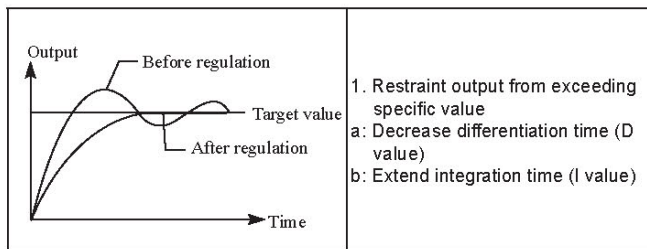

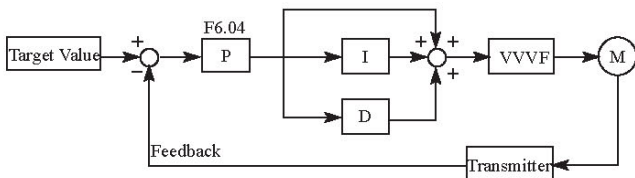
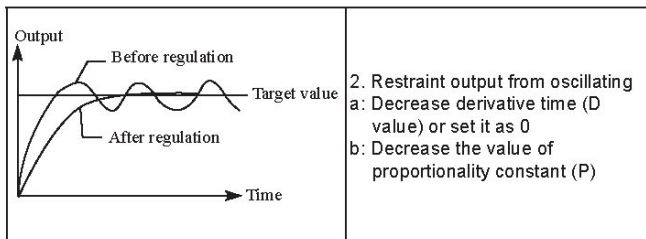

F6.05	PID upper alarm value		default: 0	
	Range	0.0 – 100%	Unit	0.1

PID upper alarm value is suitable for abnormality alarming. When PID feedback signal value is more than PID upper alarm value, the corresponding multi-functional output will inform user to handle, and Inverter will not stop as well.

F6.06	PID lower alarm value		default: 0	
	Range	0.0 – 100%	Unit	0.1

PID lower alarm value is suitable for abnormality alarming. When PID feedback value is less than the lower setting value, the corresponding multi-functional output will be for alarming, and will not shut down Inverter.

F6.07	PID P value		default: 100%	
	Range	0 – 200%	Unit	0.1

P value (proportionality constant) sets error value gain, which will be for proportional control if the value of I and D is set as 0.

F6.08	PID I value			default: 0.3s
	Range	0.0 – 200.0S	Unit	0.1s

I value (integration time) sets the response speed of action. The more I value is, the slower the response speed is. If I value is set litter, oscillation will happen by rapid response. While I value is set as 0, which indicates shut-down.

F6.09	PID D value			default: 0
	Range	0.00 – 20.0	Unit	0.01

D value (differentiation time) sets the attenuation in PID. The more D value is. The more the attenuation effect is. If D value is set as 0, which indicates shut-down.

F6.10	PID action step-length			default: 0.10
	Range	0.00 – 1.00HZ	Unit	0.01

PID is figured out once every 10ms. Frequency increment will be figured out (Δ FHZ) every time. While frequency increment is more than the value of F6.10 in maximum of frequency increment, F6.10 will work.

F6.11	PID stand by frequency			default: 0.00
	Range	0.00 – 120.00HZ	Unit	0.01

F6.12	PID stand by duration			default: 10.0
	Range	0.0 – 200.0s	Unit	0.1

F6.13	PID wake-up value			default: 00%
	Range	0.0 – 100%		

F6.11 PID stand-by frequency.

F6.11 must reach minimum frequency in PID stand-by. When running frequency is less than value of F6.11, PID stand-by duration will begin counting.

F6.12 PID stand-by duration.

When this setting enters into stand-by situation, the controller needs

to operate the duration in stand-by frequency. Under such situation when it's running time over F6.12 setting value (stand-by duration), controller will enter stand-by status and stop outputting, turn off PID. But still continually to monitor F6.13 PID feedback status.

F6.13: PID wake-up value.

After controller entered stand-by status, it still monitors PID feedback. But when controller detects that feedback value is lesser than wake-up value (F6.13), PID function will turn on, and the controller starts operating.

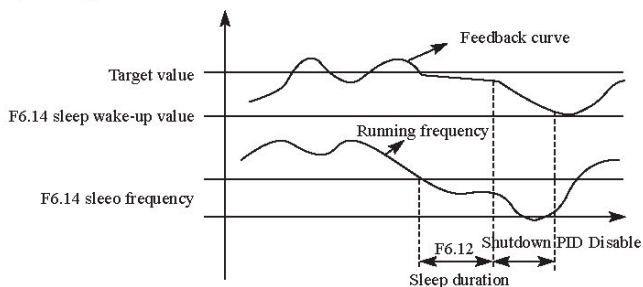

Example: target value is 60% (0 – 100% is corresponding to 0 – 10V), and wake-up value is 80%, which is actually corresponding to 0 – 10V, then the actual wake-up value is $60\% \times 80\% = 48\%$ (corresponding to 0 – 10V).

F6.14	PID corresponding value of display			default: 1000	
	Range	0 – 1000	Unit	1	
F6.15	PID digit of display			default: 4	
	Range	0 – 5	Unit	1	
	0: Not display PID feedback value 2: Display 2 digits 4: Display 4 digits		1: Display 1 digit 3: Display 3 digits 5: Display 5 digits		
F6.16	PID decimal digit of display			default: 1	
	Range	0 – 4	Unit	1	

	Content	0: Not display after decimal point 1: Display 1 digit after decimal point 2: Display 2 digits after decimal point 3: Display 3 digits after decimal point 4: Display 4 digits after decimal point
--	---------	---

F6.14 sets PID corresponding value of display.

F6.14 setting value is corresponding to + 10V analog voltage.

If F6.14 is set as 200, which indicates full span are 200, corresponding to + 10V voltage.

F6.15 sets PID digit of display

0 indicates not to display feedback value. User may select the digit of display according to actual need.

F6.16 sets PID decimal digit of display.

Example: Four-digit display is required for displaying 1 digit after decimal point, and target value is set as 50%, and PID corresponding value of display is 200.

Then, the display value is $200 \times 50\% = 100.0$. The parameter group is convenient for user to monitor.

Parameter: F6.14 = 200; F6.15 = 4; F6.16 = 1.

F6.17	PID upper limit frequency		default: 48.00	
	Range	0~maximum frequency	Unit	0.01
F6.18	PID lower limit frequency		default: 20.00	
	Range	0~maximum frequency	Unit	0.01
F6.19	PID working mode		default: 0	
	Range	0: PID turn on, nonstop working 1:PID turn on, when feedback achieves F6.05, will use the Minimum of frequency to work; when it turn down to F6.06, PID will return counting.	Unit	1
F6.20	Bias limitation		default: 0	
	Range	0~10.0%	Unit	0.1%

F6.20 parameter instruction:

Limitation of pressure regulation deviation: the maximum deviation

of pressure regulating output value in correspondence with sett pressure loop value.

F6.17 PID upper limit frequency

When turn on PID and the controller running, if output frequency (FOUT) bigger than its parameter F6.17, and its duration more than one minutes. The multi-function output symbol- 29(Constant pressure and water supplying) as 1, represent turn on. If F3.25 set as 29, then the relay terminal YB and YC will take action.

F6.18 PID lower limit frequency

When turn on PID and the controller running, if output frequency (FOUT) smaller than its parameter F6.18, and its duration more than one minutes. The multi-function output symbol- 29(Constant pressure and water supplying) as 0, represent turn off. If F3.25 set as 29, then the relay terminal YB and YC will not take action.

Application example: application of F6.17、F6.18 can carry out supplying water with constant pressure in single-split type, one is variable frequency' another is industrial frequency. F3.25 set as 29, relay contact YB、YC control the running of industrial frequency motor.

Running procedure: when the output frequency of running reach F6.17 and last more than one minute, the relay contact YB、YC connect' and the industrial frequency motor runs to increase the hydraulic pressure. When controlling output frequency of running low down to F6.18 and last for more than one minute, relay contact YB、YC disconnected, the industrial frequency motor stops.

F6.17 PID working mode

To set as 0: When turn on PID, begin to read the target and feedback values and PID counting then will revise running frequency.

To set as 1: When turn on PID, begin to read the target and feedback value, and PID counting then will revise running

frequency. However, when feedback achieves F6.05, PID will not start counting, but will choose minimum of frequency to working. But when it turns down F6.06, PID will start counting again.

F6.20	KB1, KA1	default 2		
F6.21	KB2, KA2	default 1		
F6.22	KB3, KA3	default 4		
F6.23	KB4, KA4	default 3		
F6.24	KB5, KA5	default 6		
F6.25	KB6, KA6	default 5		
F6.26	KB7, KA7	default 8		
F6.27	KB8, KA8	default 7		
	Range	0-14	Unit	
	Content	0. Ineffective 1.Contact Point of Motor A Industrial frequency 2.Contact Point of Motor A Convertible frequency 3.Contact Point of Motor B Industrial frequency 4.Contact Point of Motor B Convertible frequency 5.Contact Point of Motor C Industrial frequency 6.Contact Point of Motor C Convertible frequency 7.Contact Point of Motor D Industrial frequency 8.Contact Point of Motor D Convertible frequency 9.Contact Point of Motor E Industrial frequency 10.Contact Point of Motor E Convertible frequency 11.Contact Point of Motor F Industrial frequency 12.Contact Point of Motor F Convertible frequency 13.Contact Point of Motor G Industrial frequency 14.Contact Point of Motor G Convertible frequency		

Setting a pump with convertible frequency function needs two control signals (industrial and convertible frequency). And setting a pump with industrial frequency function or with sleep mode needs one control signal of industrial frequency.

F6.28	Time second setting			
	Range	0 ~ 60	Unit	1
F6.29	Time minute setting			
	Range	0 ~ 60	Unit	1
F6.30	Time hour setting			
	Range	0 ~ 24	Unit	1

F6.31	Time day setting			
	Range	1 ~ 31	Unit	1
F6.32	Time month setting			
	Range	1~ 12	Unit	1
F6.33	Time year setting			
	Range	00 ~ 99	Unit	1
F6.34	A pump			default 1
F6.35	B pump			default 1
F6.36	C pump			default 1
F6.37	D pump			default 0
F6.38	E pump			default 0
F6.39	F pump			default 0
F6.40	G pump			default 0
	Range	0-3	Unit	
	Content	0: ineffective 1: for convertible frequency 2: for industrial frequency 3. for sleep mode		

0: the pump is ineffective

A corresponding pump does not work.

1: Convertible frequency pump

Start a corresponding pump. Based on the condition of non-switch another pump, the corresponding pump will adjust variables in a whole constant pressure system. According to actual pressure of the system, the inverter would auto adjust the speed to maintain constant pressure. The pump will switch to industrial frequency running or non-working on the switching condition.

2: Industrial frequency pump

All of the corresponding pump will run industrial frequency mode. The power is supplied from supply network.

3: Sleep pump

The corresponding pump will be sleeping on setting condition.

According to the sleep pressure and the allowance, the pump will auto get to sleep or wake up.

F6.41	Pressure allowance of pump up			default 5.00
	Range	0 ~ 25.0%	Unit	0.1
F6.42	Running frequency of pump up			default 48.00Hz
	Range	0 ~ max frequency	Unit	0.01
F6.43	Delay time of pump up			default 10S
	Range	0 ~ 3600.0S	Unit	1
F6.44	Reserved			

The above parameters are used to setting conditions of pump up.

- 1: It will carry out pumping up that feedback pressure < pressure setting value – pressure allowance after F6.43 delay time on condition of a convertible frequency pump runs to F6.42.
- 2: If next one is another convertible frequency pump, the inverter will switch to run in industrial frequency by the time of pull gate (F6.50), then it will start to run next one by conjunction gate (F6.51)
- 3: If next one is an industrial frequency pump, the inverter will speed down to the time of pump down (F6.46), and then carry out running the PID pressure adjustment.

F6.45	Pressure allowance of pump down			default 5.00
	Range	0 ~ 25.0%	Unit	0.1
F6.46	Running frequency of pump down			default 48.00Hz
	Range	0 ~ max frequency	Unit	0.01
F6.47	Delay time of pump down			default 10S
	Range	0 ~ 3600.0S	Unit	1
F6.48	Reserved			

The above parameters are used to setting conditions of pump up.

It will carry out pumping down that feedback pressure > pressure setting value + pressure allowance after F6.47 delay time on condition of a convertible frequency pump runs to F6.46.

Timing cycle: it is regularly changed pump water. Setting F6.43 for 0 will not carry out pumping up. Setting F6.47 for 0 will not carry out pumping down.

F6.49	Time of injunction gate			default 1.0
	Range	0 ~ 10 S	Unit	0.1
F6.50	Time of pull gate			default 1.0
	Range	0 ~ 10 S	Unit	0.1
F6.51	Circuit time			default 480
	Range	0 ~ 65535 min	Unit	1

1. Time of injunction gate is from getting the contact close to inverter start time, in order to delay time of starting next one inverter.

2. Time of pull gate is from getting free stop to contact open time.

F6.52	Start time T1			default 0
F6.53	Start time T2			default 0
F6.54	Start time T3			default 0
F6.55	Start time T4			default 0
F6.56	Start time T5			default 0
F6.57	Start time T6			default 0
F6.58	Start time T7			default 0
F6.59	Start time T8			default 0
	Range	00 ~ 23:59	Unit	0.1

3. Setting circuit time for 0 will be ineffective.

F6.60	Pressure 1			default 40.0
F6.61	Pressure 2			default 20.0
F6.62	Pressure 3			default 20.0
F6.63	Pressure 4			default 20.0
F6.64	Pressure 5			default 20.0
F6.65	Pressure 6			default 20.0
F6.66	Pressure 7			default 20.0
F6.67	Pressure 8			default 20.0
	Range	00 ~ 23:59	Unit	0.1

The above parameters are used to time setting of multi-pressure water supply and pressure setting of corresponding time.

Principle of time setting: $T1 < T2 < T3 < T4 < T5 < T7 < T8$

F6.68	Sleep section mode			default 255
	Range	0 ~ 255	Unit	1

1. It will be ineffective as setting for 0.

2. Select the sleep section during 1 to 8 parts (binary) Multi-section is acceptable.

Setting mode: $T8 - T7 - T6 - T5 - T4 - T3 - T2 - T1$

F6.69	Sleep pressure allowance			default 5
	Range	0 ~ 25%	Unit	1
F6.70	Sleep continual time			default 30
	Range	0 ~ 3600.0S	Unit	0.1
F6.71	Sleep frequency			default 22
	Range	0 ~ max frequency	Unit	1

1. The sleep pump will stop when feedback pressure > setting pressure as it is running.

2. The sleep pump will restart when feedback pressure < setting pressure – F6.69 as it stops.

3. In time section of opening sleep mode, the sleep pump will get sleeping when running frequency is less than F6.71; feedback pressure > setting pressure – F3.69 ; continual time is more than F6.70.

4. The sleep pump will stop when feedback pressure < setting pressure – F6.69.

7-8 Communication parameter group

F7.00	Rate of communication data			default: 0
	Range	0 – 3	Unit	1
	Content:	0: 4800bps 2: 19200bps	1: 9600bps 3: 38400bps	

F7.00 is used in transferring rate of serial communication. Note: in adopting serial communication, the same transfer rate must be

guaranteed for both parties in communication.

F7.01	Mode of communication data			default: 0
	Range	0 – 5	Unit	1
	Content	0: 8N1 For ASC 2: 8O1 For ASC 4: 8E1 For RTU	1: 8E1 For ASC 3: 8N1 For RTU 5: 8O1 For RTU	

F7.01 sets the format of communication data. Please see related communication specification in detail.

F7.02	IP address of communication			default: 0
	Range	0 – 240	Unit	1

Every Inverter must have an address, which will be defined by F7.02. Communication control of Inverter can connect with 240 others.

F7.02 is set as 0, communication function is ineffective.

Series MODBUS communication agreement

Communication agreement is with MODBUS ASCII (American standard code for information interchange) mode: Every byte consists of 2 ASCII characters. For example: The expression of the numerical value of 54Hex ASCII is that “54” consists of “5” (35Hex) and 4(34 Hex).

1. Definition of coding

Communication agreement belongs to hexadecimal system, of which each character represents the following information.

Character	“0”	“1”	“2”	“3”	“4”	“5”	“6”	“7”
ASCII code	30H	31H	32H	33H	34H	35A	36A	37A
Character	“8”	“9”	“A”	“B”	“C”	“D”	“E”	“F”
ASCII code	38A	39H	41H	42H	43A	44A	45H	46H

2. Character structure

10 – Bit character box (For ASCII)

Data type: 8N1 For ASCII

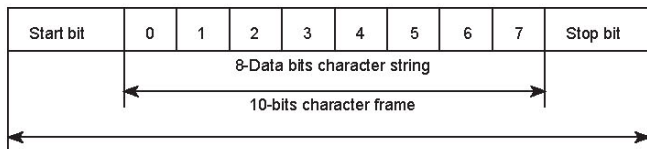

10 – Bit character frame (For RTU)

Data type: 8N1 For RTU

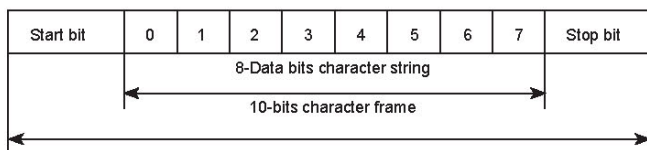

Data type: 8O1 For ASCII

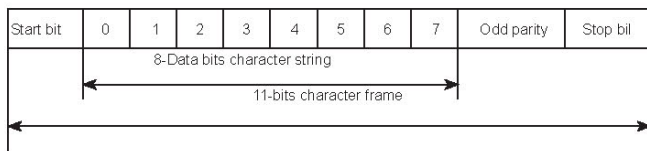

Data type: 8E1 For ASCII

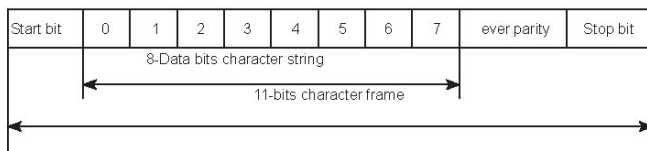

Data type: 8O1 For RTU

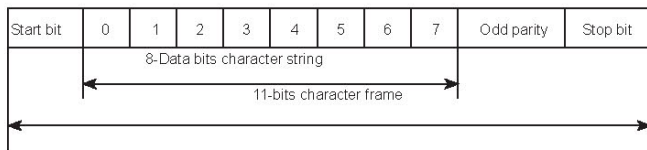

Data type: 8E1 For RTU

Operation Instruction of YMP Series Inverter

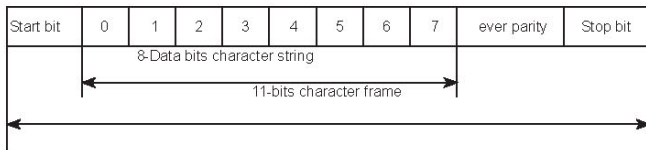

3. Structure of communication data

Data format frame

ASCII mode:

STX	Start character = ':'(3AH)
Address Hi	Communication address: 8-bit address consists of 2 ASCII codes
Address Lo	
Function Hi	Function code: 8-bit function code consists of 2 ASCII codes
Function Lo	
DATA (n-1)	Data characters: $n \times 8$ -bit data content consists of $2n$ ASCII codes $n \leq 16$, with the maximum of 32 ASCII codes
.....	
DATA 0	
LRC CHK Hi	LRC Check: 8-bit LRC Check consists of 2 ASCII codes
LRC CHK Lo	
END Hi	End character:
END Lo	END Hi = CR (0DH), END Lo = LF (0AH)

RTU mode:

START	Keep that zero-input signal is more than or equal to 10 ms
Address	Communication address: 8-bit binary address
Function	Function code: 8-bit binary address
DATA (n-1)	Data characters: $n \times 8$ -bit data, $n = 16$
.....	
DATA 0	
CRC CHK Low	CRC Check: 16-bit CRC Check consists of 2 8-bit binary systems
CRC CHK High	
END	Keep that zero-input signal is more than or equal to 10 ms

Communication Address

00H: All driver Broadcasts

01H: For Inverter with 01st address

0FH: For Inverter with 15th address

10H: For Inverter with 16th address, by analogy, the maximum can reach 240.

Function code and Data Characters

03H: Read out content of temporary storage

06H: Write a WORD into temporary storage. Function code 03H: Read out content of temporary storage.

For example: For driver address 01H, read out the data characters in 2 successive temporary storages as follows: Initial temporary storage address is 2102H

ASCII mode:

Format of enquiry message character Format of response message character

string:

STX	'0'
Address	'1'
	'0'
Function	'0'
	'3'
Starting address	'2'
	'1'
	'0'
Number of data (count by word)	'2'
	'0'
	'0'
	'0'
IRC Check	'2'
	'D'
END	'7'
	CR
	LF

string:

STX	'0'
Address	'1'
	'0'
Function	'0'
	'3'
Number of data (count by byte)	'0'
	'4'
Content of starting address 2102H	'1'
	'7'
	'7'
	'0'
Content of address 2103 H	'0'
	'0'
	'0'
	'0'
LRC Check	'7'
	'1'
END	CR
	LF

RTU mode:

Format of enquiry message:
response message:

Format of

Operation Instruction of YMP Series Inverter

Address	01H
Function	03H
Starting data address	21H
	02H
Number of data (count by word)	00H
	02H
CRC CHK Low	6FH
CRC CHK High	F7H

Address	01H
Function	03H
Number of data (count by byte)	04H
Content of data address 8102H	17H
	70H
Content of data address 8103H	00H
	00H
CRC CHK Low	FEH
CRC CHK High	5CH

Function code 06H: Write a WORD into temporary storage.

For example: For driver address 01H, write 6000 (1770H) into the internal parameter 0100H of driver.

ASCII mode:

Format of enquiry message character string:

STX	':'
Address	'0'
	'1'
Function	'0'
	'6'
Data address	'0'
	'1'
	'0'
	'0'
STX	':'
Data content	'1'
	'7'
	'7'
	'0'
LRC Check	'7'
	'1'
END	CR
	LF

Format of response message character string:

STX	':'
Address	'0'
	'1'
Function	'0'
	'6'
Data address	'0'
	'1'
	'0'
	'0'
STX	':'
Data content	'1'
	'7'
	'7'
	'0'
LRC Check	'7'
	'1'
END	CR
	LF

RTU mode:

Format of enquiry message:
response message:

Format of

Address	01H
Function	06H
Data address	01H
	00H
Data content	17H
	70H
CRC CHK Low	86H
CRC CHK High	22H

Address	01H
Function	06H
Data address	01H
	00U
Data content	17H
	70H
CRC CHK Low	86H
CRC CHK High	22H

LRC Check of ASCII mode

LRC Check is the value added from Address to Data Content. For example, the LRC Check of the above 3.3.1 inquires message: 01H + 03H + 21H + 02H + 00H + 02H = 29H, then the complement of 2 (D7H) is taken.

CRC Check of RTU mode

CRC Check is from Address to Data content, and its running rule is as follows:

Step 1: Make 16-bit temporary storage (CRC temporary storage) = FFFFH.

Step 2: Exclusive OR first 8-bit byte message instruction and low 16-bit CRC temporary storage: Perform Exclusive OR, and store the result into CRC temporary storage.

Step 3: Shift right CRC temporary storage and fill 0 into high bit position.

Step 4: Check right shift value. If being 0, store the new value for step 3 into CRC temporary storage. Otherwise in case of Exclusive OR A001H and CRC temporary storage will store the result into CRC temporary.

Step 5: Repeat Step 3 ~ Step 4, and operate completely for 8-bit.

Step 6: Repeat Step 2 ~ Step 5, and take the message instruction for next 8-bit until all message instructions are operated completely.

Finally, the value gotten of CRC temporary storage is CRC Check.

CRC Check must be placed into the check mode of message instruction interchangeably.

The following is the example of CRC Check running written in C language:

```

unsigned char * data ←//Message instruction pointer
unsigned char length ←//Length of message instruction
unsigned int crc_chk(unsigned char * data,unsigned char length)
{
    int j;
    unsigned int reg_crc=0Xffff;
    while (1length--){
        reg_crc^=*data ++;
        for (j=0; j<8; j++) {
            if (reg_crc & 0x01) { /*LSB (b0) =1 */
                reg_crc= (reg_crc>>1) ^0Xa001;
            }else{
                reg_crc=reg_crc>>1;
            }
        }
        return reg_crc; //Finally feedback the value of CRC temporary
    }
}

```

7-9 Parameters for Advanced Application

F8.00	Advanced application of Lock-in parameter			default: 1
	Range	0 – 1	Unit	1
	Content	0: Lock 1: Unlock		

Set F8.00, Advanced application of Lock-in parameter avoids misoperating, which may result in negative consequences.

F8.01	50Hz/60Hz system setting			default: 0
	Range	0 – 1	Unit	1
	Content	0: 50Hz 1: 60Hz		

50Hz/60Hz system can be set by the parameter according the

condition of electric network.

F8.02	Selection of constant and variable torque			default: 0
	Range	0 – 1	Unit	1
	Content	0: Constant torque 1: Variable torque		

F8.02 can work switch constant torque, or variable torque, which is suitable for different loads, protection level and related parameter.

F8.03	Setting of over-voltage protection level default: Three phaseAC380V 650.0 One phaseAC220V 375			
	Range	Three phaseAC380V760K – 820.0V One phaseAC220V370.0V~420.0V	Unit	0.1

F8.03 sets over-voltage protection level. Inverter tends to meet over-voltage protection in low electric network. For the above situation, the protection level may be adjusted down to guarantee normal running of Inverter.

F8.04	Setting of low-voltage protection level default: Three phaseAC380V 400 / One phaseAC220V 200			
	Range	Three phaseAC380V:380.0V~450.0V One phaseAC220V: 160.0V~220.0V	Unit	0.1

F8.04 sets voltage protection level. Inverter tends to meet low-voltage protection in low electric network. Thus the value of F8.04 may be adjusted down to guarantee normal running of Inverter.

F8.05	Setting of excess-temperature protection level			default: 85°C/95°C
	Range	40 – 120	Unit	1

F8.05 sets the excess-temperature protection level of Inverter. In high temperature environment, the protection level may be adjusted up to normal running of Inverter. However, much higher setting will cause damage. The only solution is to increase effect of heat elimination for the goal of cooling-down.

F8.06	Setting display of current filtering time			default: 2.0
	Range	0 – 100	Unit	1

This parameter setting is related to the stabilization of current display, please do not modify in general situation. If the setting is much lower, current display will fluctuate.

F8.07	0 – 10V Analog output low-end correction factor			default: *
	Range	0 – 65535	Unit	1
F8.08	0 – 10V Analog output high-end correction factor			default: *
	Range	0 – 65535	Unit	1
F8.09	0 – 20mA Analog output low-end correction factor			default: *
	Range	0 – 65535	Unit	1
F8.10	0 – 20mA Analog output high-end correction factor			default: *
	Range	0 – 65535	Unit	1

The above parameters are default settings. Thus shall not be corrected, otherwise it will cause abnormal running of Inverter.

F8.11	Interval compensation frequency point			default: 0.00
	Range	0 – maximum operation frequency	Unit	1
F8.12	UP/DOWN frequency memory selection			default: 0
	Range	0: stored 1: not stored	Unit	1

F8.11 forward/reverse operation compensation frequency point

The running frequency is lower than the set-up value, which will increase the forward/reverse operation compensation. The suggestion for the set-up value is above 10.00Hz.

F8.12 UP/DOWN frequency memory selection

When choosing “UP/DOWN” to set up the frequency, the parameter is set as 0, and the frequency remain the same after stopping. The parameter is set as 1, and the frequency become 0 after stopping.

Chapter 8 Maintenance, Fault Diagnosis and Countermeasure

Please keep regular maintenance of Inverter for normal condition.

8-1 Daily checking items

- (1) Sound and vibration in motor.
- (2) Heat on motor.
- (3) Completion of power supply wire and machine electrical wire.
- (4) Completion of wire and connection of terminal wire.
- (5) Cleanliness inside Inverter.
- (6) Fan of Inverter.
- (7) Air temperature and humidity of installation.
- (8) Cleanliness on radiator.
- (9) Inverter output electric current and displayed current.
- (10) Sound or vibrating in running.

8-2 Maintenance and checking notice

- (1) When maintaining, please make sure the power supply is off.
- (2) Cutting off the power supply, wait for internal high pressure instructive light goes off, then check and maintain.
- (3) In the process of checking and maintenance, not to leave screws and other fittings in Inverter.
- (4) Please keep Inverter clean and dry.
- (5) In checking and mending, please not to mismatch the wires, otherwise it will lead Inverter not to work or break down.

8-3 Regular checking items

Checking items	Checking content	Countermeasure
terminal, screw, connective plug	loose	Screw fasten
Radiator	dust	Blow off with dry compressed air (4-6kgcm ²)
Heat sinker	sound and vibration, and working duration over 20,000 hours	Replace
Circuit board	dust and rust	Blow off with dry compressed air (4-6kgcm ²) or contact maker.
Electrolysis capacitor	color change, smell and plump up	Replace
Electromotor	Vibration, heat, noise, smell.	Check or replace

8-4 Regular Replacement

Inverter is made up by many parts, in accordance with condition, some of which need maintenance for normal running of Inverter. To keep Inverter working normally in a long term, some fittings need to be replaced regularly according to their life. Replace time for your reference is as follow:

Fitting's name	Replace period	Handling measure
Heat sinker	3-5 years	Replace (decide after checking)
Electrolysis capacitor	5 years	Replace (decide after checking)
Fuse	10 years	Replace (decide after checking)
Relay	—	Decide after checking

The hereinbefore fittings' replace circle is reckoned in the following environment:

- (1) Annual average surrounding temperature is 30°C. There is no corrosive gas, flammable gas, oil fog, dust, drips, or etc;
- (2) The load factor is below 80%;
- (3) The average working time is below 12 hours.

8-5 Protective Information, Fault Diagnosis and Remove.

Inverter has complete protective functions, such as over voltage, over currency, over load, over heat, short circuit to the ground, short circuit and etc. When Inverter gets error, there must be some reasons, please find out the reason and remove the error. Restart after dealing with the error. If there are other questions, please contact us in time.

Error code	Content	Possible reason	Solution
OC1 UC1	Over currency in acceleration	1: Much short Acceleration time 2: disarrangement of V/F curve. 3: Motor wire with short circuit to ground 4: Over high of Torsion lift 5: Over low of Electric net voltage. 6: Directly start in running motor 7: Disarrangement of controller 9: Controller failed	1: Extend acceleration time 2: Correct V/F curve. 3: Check insulation of motor wire. 4: Reduce the value of torsion lift. 5: Check electric net 6: Check load 7: Set tracking start 8: Increase capacity of controller 9: Sent for repairing
OC3 UC3	Over currency in running	1: Insulation of motor wire 2: Fluctuation of load 3: Fluctuation of electric net and the low voltage 4: Disarrangement of capacity 5: Higher power motor starting up 6: Disturbing resource	1: Check insulation of motor wire 2: Check blocking or bad lubrication in loading condition 3: Check electric net voltage 4: Increase capacity of controller 5: Resolve capacity of transformer 6: Resolve disturbing resource
OC2 UC2	Over current in deceleration	1: much short deceleration time 2: Disarrangement of capacity 3: Disturbing resource	1: Extend acceleration time 2: Increase capacity of controller 3: Resolve disturbing resource
OU0	Over voltage in stopping	1: Much short Acceleration time 2: Disarrangement of capacity 3: Disturbing resource	1: Check power supply voltage 2: Sent for repairing

Error code	Content	Possible reason	Solution
OC0 UC0	Over currenxy in stopping	1: Controller failed	1: Sent for repairing
OU1	Over voltage in acceleration	1: Abnormal power supply 2: improper circuitry 3: Controller failed	1: Check power supply voltage 2: Do not use power supply switch controller on or off 3: Sent for repairing
OU3	Over voltage in running	1: abnormal power supply voltage 2: Energy feedback load 3: Disarrangement of braking resistance	1: Check power supply voltage 2: Install braking unit and resistance 3: Affirm resistance setting again
OU2	Over voltage in deceleration	1: Much short deceleration time 2: abnormal power supply voltage 3: Over load 4: Disarrangement Braking resistance or parameter	1: Extend deceleration time 2: Check power supply voltage 3: Check braking unit and resistance 4: Set braking resistance over again 5: Correctly set parameter, e.g. braking tube voltage, etc.
LU0	Low voltage in stand-by	1: abnormal Power supply voltage 2: Phase missing	1: Check power supply voltage 2: Check power supply and switch
LU1	Low voltage in acceleration running deceleration	1:abnormal power supply voltage 2: Phase missing 3: Over low of Electric net voltage	1: Check power supply voltage
LU2			2: Check connection
LU3			3: Please use independent power supply
Fb0 Stop Fb1 Acc. Fb2Dec. Fb3 Run	Broken fuse	1: Controller failed	1: Sent for repairing

Error code	Content	Possible reason	Solution
OL0 not in running OL2 in DC OL3 in running OL1 in acc	Controller over load Model A: 150%,60S Model P: 120%,60S	1: Over load 2: Much shorter Acceleration time 3: Much quicker torsion lifting 4: Disarrangement of V/F curve 5: Low voltage of electric net 6: controller starts before motor stops. 7: Fluctuation or blocking in loading	1: Reduce load or replace larger capacity of controller 2: Extend acceleration time 3: Reduce torsion lifting rate 4: Reset V/F curve over 5: Check electric net voltage; increase controller capacity 6: Adopt track start mode 7: Check load condition
OT0 not in running and not reach over torque T1 in acc OT2 in DC OT3 in running	Motor over load	1: Over load 2: Much shorter acceleration time 3: Much lower Motor protection level 4: Disarrangement of V/F curve 5: Much quicker torsion lifting 6: Bad motor insulation 7: Disarrangement of motor	1: Reduce load 2: Extend acceleration time 3: Extend protection setting 4: Correct V/F curve 5: Reduce torsion lifting rate 6: Check motor insulation and replace motor 7: Use larger controller and motor
OH0 not in running OH1 in acc OH2 in DC OH3 in running	Controller over heat	1: Broken radiator fan 2: Blocked radiator fan pipe 3: High temperature of environment 4: Bad aeration 5: More narrow installation space	1: Replace radiator fan 2: Clean up wind pipe and radiator 3: Improve aeration condition and reduce wave frequency 4: Improve aeration condition and air convection 5: Improve installation location and aeration condition
ES	Emergency stop	1: Under condition of emergency stop	1: After settling emergency stop, start up as regular procedure
CO	Wrong communication	1: Bad connection 2: Disarrangement of communication parameter 3: Wrong transmission format	1: Check connection line 2: Reset parameter 3: Check data transmission format

Error code	Content	Possible reason	Solution
20	4-20mA broken wire	1: Loose terminal and bad connection	1: Check connection line and link the broken down wire
Pr	Wrong Parameters	1.Parameters are set wrong	1.Correct to set the parameters
Err	Wrong Parameters	1.The parameters are not existent	1.Quite the parameters

8-6 Remove Regular Error

(1) Parameter cannot be set

Reason and solution:

- A: Lock the parameter, and set F1.18 for 0, and then set other parameters.
- B: Running machine communicates abnormally. Reinstall running machine and check whether the connection line is broken down.
- C: Machine is running, and parameter cannot be set. Please stop the machine and set.

Press "run" (external control) but the motor does not run

(2) Reason and solution:

- A: Wrong running mode, please check if F1.02 is set for 1.
- B: Frequency order is not given or the frequency is below the start frequency.
- C: Peripheral connection mistake, please check peripheral connection.
- D: The definition of Inverter input terminal is wrong, and not match peripheral connection. Check 3.15-F3.22 parameter.
- E: Start button is fault and controlling wire is broken. Check control wire and button.
- F: Inverter is in protection and is not reset. Please reset and restart.
- G: Motor connection is not connected or phase missed. Check motor connection.

H: Motor is fault. Please check if the motor is broken down.

I: Inverter is fault. Please check the mistake of Inverter.

(3) Motor over heat

Reason and solution:

A: Higher temperature of environment. Please improve the condition and aeration, and reduce temperature.

B: Much heavier load. The actual load is over the motor rating torsion. Enlarge the motor capacity.

C: The insulation of motor declines. Replace the motor.

D: The distance between Inverter and motor is too long. Please reduce the distance and install anti-alternating current machine.

E: Voltage resistance between motor phases is not sufficient. Inverter will generate impact voltage between motor loops in switching. The maximal impact voltage will reach 3 times more than input voltage. Recommend using specialized motor.

F: When the running motor in a low speed to change the deceleration rate, motor will run in a high speed.

(4) Machine vibration or abnormal sound

Reason and solution:

A: Blocking or bad lubrication of the machine. Please check machine load.

B: The machine has a sympathetic vibration phenomenon. Adjust the carrier wave, change deceleration rate, avoid sympathetic vibration frequency, and install shock absorption level up.

(5) The motor does not allow reverse.

Reason and solution:

A: Reverse is forbidden. Release the forbiddance.

(6) Motor allows reverse.

Reason and solution:

- A: Exchange both of three terminals U, V, W. on Inverter output
- B: Reverse the running controlling signal. If the original signal is positive, set it negative.

(7) Inverter starts up and disturbs other settings

Reason and solution

Reason: Inverter disturbing

Solution:

- A: Reduce carrier frequency
- B: Install filter on supply input terminal of Inverter power
- C: Install filter on power supply output terminal of Inverter
- D: Correct grounding from motor and Inverter
- E: Separate main circuit connection and other signal connection
- F: Adopt control connection with shield connection. Cable should be covered metal tube
- G: The terminals of connection input and output should be installed magnetic loop

8-7 Disturbance solution

The regular disturbance includes two kinds: one is Inverter disturbs other equipments and instrument, which refers to 8-6; the other is Inverter is disturbed and make controller take wrong action.

Bringing disturbance must be disturbing resource and channel. The disturbing channel of Inverter is as the same as other electromagnetic disturbing channel, mainly referred to electromagnetic radiation, transmission, inductance coupling.

(1) Electromagnetic radiation

Generate electromagnetic radiation to the surrounding electron and electronic equipment. The shield can be one of the solutions.

(2) Transmission

Generate electromagnetic noise to directly driving motor and transmit disturbance to power supply, and transmit it to other device through electronic net. Filter wave may solve the problems.

(3) Inductance coupling

Generate inductance coupling to other connections

The concrete solution for disturbance

(1) Insulation

Separate disturbing resource from those easily affected parts. Electric welding machine is a strong disturbing resource. Description of Inverter says that the electric welding machine and Inverter cannot share the same power supply.

(2) Wave filter

The filter is installed for restraining the disturbing signal to be transmitted from Inverter to power supply and motor through power supply wire transmission. The solution is to add filter, reactor or magnetic loop at the input and output ends.

(3) Shield

Inverter adopts iron casing shield not to let electromagnetic disturbance leak. The output wire adopts iron tube shield; control wire adopts shield wire; power supply wire is separated from control wire, etc.

(4) Grounding

Good grounding may significantly prevent the break of external disturbance, restrain internal coupling and raise the system capability of anti-disturbance.

The following illustration is Inverter transmission system countermeasure of anti-disturbance:

8-8 Failure Records

Status	Failure Record	Display figure
IGBT gets over current in checking	Big letters "OC0"	64
	Big letters "OC1"	65
	Big letters "OC2"	66
	Big letters "OC3"	67
CT gets over current in checking	Small letters "oc 0"	68
	Small letters "oc 1"	69
	Small letters "oc 2"	70
	Small letters "oc 3"	71
Over voltage	OU0	80
	OU1	81
	OU2	82
	OU3	83
Cut fuse off	FB0	84
	FB1	85
	FB2	86
	FB3	87
Lacking voltage	LU0	88
	LU1	89
	LU2	90
	LU3	91
Over load	OL0	92
	OL1	93
	OL2	94
	OL3	95
Over voltage	OT0	96
	OT1	97
	OT2	98
	OT3	99
Over heat	OH0	100
	OH1	101
	OH2	102
	OH3	103

Chapter 9 External Fittings Selection

9-1 The Purpose of Accessory

Name	Purpose
Circuit breaker Leakage switch	Protect connections of the controller for convenience, installation, protection and maintenance.
Magnetic contactor	Guarantee switching power supply of controller from damage
Surge absorber	Absorb surge electric current from electromagnetic contact and relay.
Isolating transformer	Insulate input and output of the controller for reducing disturbance.
DC reactor	Protect and restrain high frequency wave.
AC reactor	To protect the controller and restrain high frequency wave and prevent surge voltage impact.
Braking Resistance and Braking Unit	Absorb the regenerate energy.
Noise wave filter	Reduce the disturbance from controller.
Magnetic loop	Reduce the disturbance from controller

9-2 Arrangement

9-2-1 DC reactor

Controller type	Suitable power	DC reactor parameter	
		Rated current (A)	Inductance value (mH)
NZC0370T4B-Y	37	78	0.7
NZC0450T4B-Y	45	95	0.54
NZC0550T4B-Y	55	115	0.45
NZC0750T4B-Y	75	160	0.36
NZC0900T4B-Y	90	180	0.33
NZC1100T4B-Y	110	250	0.26

Controller type	Suitable power	DC reactor parameter	
		Rated current (A)	Inductance value (mH)
NZC1320T4B(G)-Y	132	250	0.26
NZC1600T4B(G)-Y	160	340	0.18
NZC1850T4B(G)-Y	185	460	0.12
NZC2000T4B(G)-Y	200	460	0.12
NZC2200T4B(G)-Y	220	460	0.12
NZC2500T4B(G)-Y	250	650	0.11
NZC2800T4B(G)-Y	280	650	0.11

Install connection:

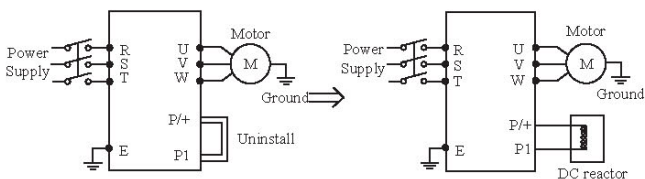

9-2-2 AC reactor

Controller type	Suitable power	AC reactor parameter	
		Rated current (A)	Inductance value (mH)
NZC0110T4B-Y	11	24	0.52
NZC0150T4B-Y	15	34	0.397
NZC0180T4B-Y	18.5	38	0.352
NZC0220T4B-Y	22	50	0.26
NZC0300T4B-Y	30	60	0.24
NZC0370T4B-Y	37	90	0.16
NZC0450T4B-Y	45	120	0.13
NZC0550T4B-Y	55	150	0.1
NZC0750T4B-Y	75	200	0.12
NZC0900T4B-Y	90	250	0.06
NZC1100T4B-Y	110	250	0.06
NZC1320T4B(G)-Y	132	290	0.04

Controller type	Suitable power	AC reactor parameter	
		Rated current (A)	Inductance value (mH)
NZC1600T4B(G)-Y	160	330	0.04
NZC1850T4B(G)-Y	185	400	0.04
NZC2000T4B(G)-Y	200	490	0.03
NZC2200T4B(G)-Y	220	490	0.03
NZC2500T4B(G)-Y	250	530	0.03
NZC2800T4B(G)-Y	280	600	0.02

Installation:

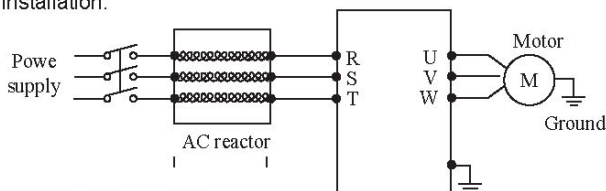

9-2-3 Braking resistance

Controller Type	Braking resistance		CDBR	Torsion (10% ED)	(KW)
	W	Ω			
NZC0055T4B-Y	500	100	Embedded	125	5.5
NZC0075T4B-Y	1000	75		125	7.5
NZC0110T4B-Y	1000	50		125	11
NZC0150T4B-Y	1500	40		125	15
NZC0180T4B-Y	1500	40	4030×1	125	18.5
NZC0220T4B-Y	4800	32	4030×1	125	22
NZC0300T4B-Y	4800	27.2	4030×1	125	30
NZC0370T4B-Y	6000	20	4030×1	125	37
NZC0450T4B-Y	9600	16	4045×1	125	45
NZC0550T4B-Y	9600	13.6	4045×1	125	55
NZC0750T4B-Y	6000×2	20×2	4045×2	125	75
NZC0900T4B-Y	9600×2	13.6×2	4045×2	125	90
NZC1100T4B-Y	9600×3	20×3	4045×3	125	110
NZC1320T4B(G)-Y	9600×3	20×3	4045×3	125	132
NZC1600T4B(G)-Y	9600×4	13.6×4	4045×4	125	160

Controller Type	Braking resistance		CDBR	Torsion (10% ED)	(KW)
	W	Ω			
NZC1850T4B(G)-Y	9600×4	13.6×4	4045×4	125	185
NZC2000T4B(G)-Y	9600×5	13.6×5	4045×5	125	200
NZC2200T4B(G)-Y	9600×5	13.6×5	4045×5	125	220
NZC2500T4B(G)-Y	9600×5	13.6×5	4045×5	125	250
NZC2800T4B(G)-Y	9600×6	13.6×6	4045×6	125	280

Calculate of braking resistance value:

The braking resistance value is related to the DC currency when Inverter braking. For 380V power supply, the braking DC voltage is 800V-820V, and for 220V system, the DC voltage is 400V.

Moreover, the braking resistance value is related to braking torsion $M_{br}\%$. The braking resistance values are different for the different braking torsion. The calculation formula is as follow:

$$R = \frac{U_{dc}^2 \times 100}{P_{Motor} \times M_{br}\% \times \eta_{Transducer} \times \eta_{Motor}}$$

Thereinto: U_{dc} ——Braking DC voltage;

P_{Motor} ——Motor power;

M_{br} ——Braking torsion;

η_{Motor} ——Motor efficiency;

$\eta_{Transducer}$ ——Transducer efficiency.

The braking power is related to braking torsion and braking frequency. The above illustration shows the braking torsion as 125% and the frequency is 10%. The different loading is by situations, the data in the illustration are for reference.

Appendix 1 Simple Application Example

1-1 Example

Use external end (three phases) to control running of Inverter, use external terminal to switch rotation forward or reverse. The potentiometer controls frequency of Inverter.

A: Basic connection illustration:

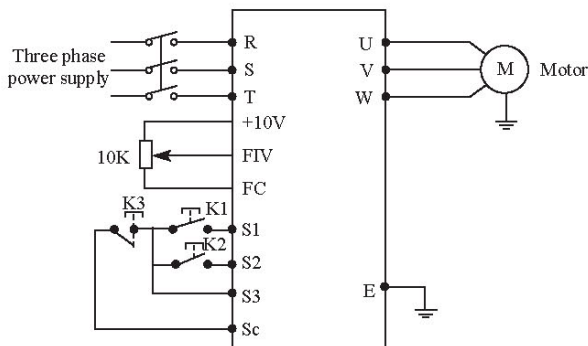

B: Parameter setting and instruction:

F1.01=1 the measure of analog voltage setting

(Potentiometer of external terminal)

F1.02=1 external terminal control

F3.17=6 define the terminal S1 turning forward

F3.18=7 define the terminal turning reverse

F3.19=8 define terminal S3 stopping

C: Action instruction:

K1 running forward

K1 running forward

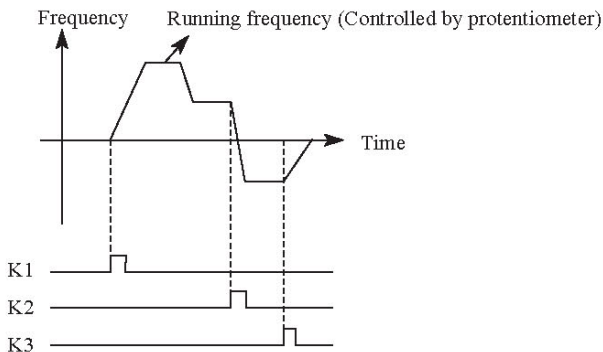

K2 running forward

K3 Stop

Running frequency is controlled by potentiometer.

1-2 Multi control function of YMP

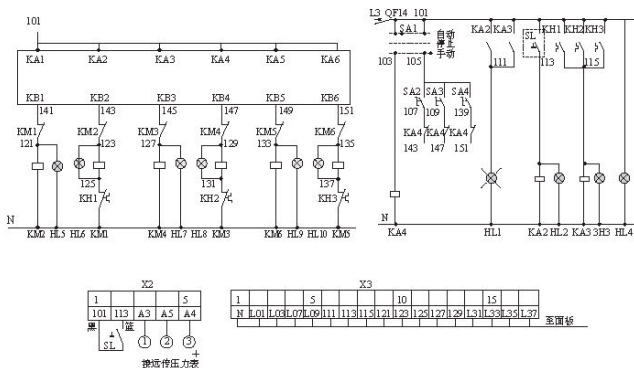

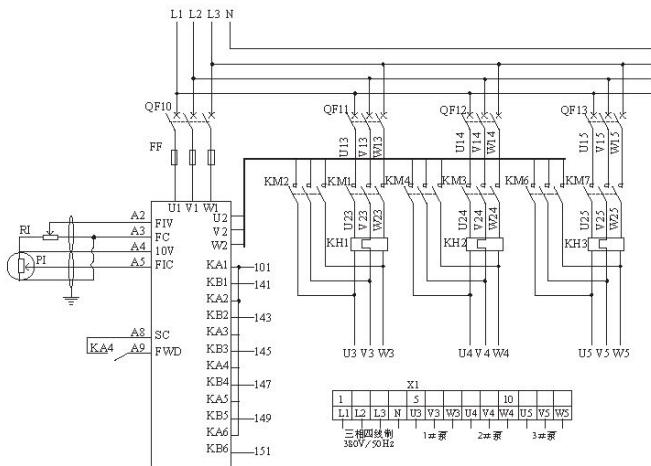

F1.01=0 ----- (operation panel gets ineffective)

F1.02=1 ----- (IO terminal works)

F1.03=0 ----- (the stop button gets ineffective)

F1.04=0 ----- (forbid reversing)

F1.06=25 ----- (minimum operating frequency)

F1.07=15 ----- (acceleration time)

F1.08=15 ----- (deceleration time)

F2.01=1 ----- (coast down)

F3.00=0 ----- (FIV minimum voltage)

F3.01=10 ----- (FIV maximum voltage)

F3.03=4 ----- (FIC minimum current)

F3.04=20 ----- (FIC maximum current)

F3.15=5 ----- (FWD defines as forward)

F6.00=1 ----- (PID works)

- F6.01=0 ----- (negative feedback mode)
- F6.02=0 ----- (figure targeted value)
- F6.03=0 ----- (FIV as feedback value)
- F6.20=2 ----- (KB1, KA1)
- F6.21=1 ----- (KB2, KA2)
- F6.22=4 ----- (KB3, KA3)
- F6.23=3 ----- (KB4, KA4)
- F6.24=6 ----- (KB5, KA5)
- F6.25=5 ----- (KB6, KA6)
- F6.41=2 ----- (pressure allowance of pump up)
- F6.60=50----- (targeted value according to actual condition)
- F6.42=48HZ----- (Running frequency of pump up)
- F6.43=8S ----- (delay time of pump up)
- F6.45=5 ----- (pressure allowance of pump down)
- F6.46=25HZ----- (running frequency of pump down)
- F6.47=2 ----- (delay time of pump down)
- F6.49=1 ----- (time of injection gate)
- F6.50=1 ----- (time of pull gate)
- F6.51=240min ----- (circuit time)
- F6.68=255----- (sleep section mode)
- F6.69=5 ----- (sleep pressure allowance)
- F6.70=60----- (sleep time)
- F6.71=25----- (sleep frequency)
- F6.73=3 ----- (wake-up)
- F6.74=3 ----- (wake-up time)

Appendix 2

Description of communication mode

FUNC 03 → Read 06 → Write

2-1. ASCII mode

	START	ADDR	FUNC	DATA	LRC	0D	0A	
Receive	:	01	03	2000,0001	XX	0D	0A	17bytes
Send in normal	:	01	03	02, 0120	XX	0D	0A	11+2*N N=2,4,6,8
Send in error	:	01	03	00	XX	0D	0A	11bytes
Receive	:	01	06	2000,0010	XX	0D	0A	17BYTES
":010620000010XX",0DH,0AH								
Send in error	:	01	06	2000,0010	XX	0D	0A	17BYTES
":010620000010XX",0DH,0AH								
Send in error	:	01	06	00	XX	0D	0A	11BYTES
":010600XX",0DH,0AH								

2-2. RTU mode

	ADDR	FUNC	DATA	CRCL,CRCH	
Receive	01	03	2000, 0001	XX,XX	8BYTES
Send in normal	01	03	02, 0120	XX,XX	5+N N=2,4,6,8
Send in error	01	03	00	XX,XX	5BYTES
Receive	01	06	2000, 0010	XX,XX	8BYTES
Send in normal	01	06	2000, 0010	XX,XX	8BYTES
Send in error	01	06	00	XX,XX	5BYTES

Error conditions:

- 1, Non-function code
- 2, the function code is lock or protected

2-3 Description of Register Address:

- 1) 2000H: Stop command
- 2) 2001H: Setting command (0~400.00HZ)
 - Frequency of F1.01=5 is from 2001H
 - Frequency of F1.01=0 is from F1.00

3) For example:

- a) Functional code F0.03(Current)
 - Address: 3 (Hexadecimal: 00H 03H)
- b) Functional code F0.05 (Speed)
 - Address: 5 (Hexadecimal: 00H 05H)
- c) Address: F1.00 (Main frequency)
 - Address: 100 (Hexadecimal: 00H 64H)
- d) Functional code F1.01 (Frequency source)
 - Address: 101 (Hexadecimal: 00H 65H)
- e) Functional code F1.07 (Acceleration time)
 - Address: 107 (Hexadecimal: 00H 6BH)
- f) Functional code F1.08 (Deceleration time)

Address: 108 (Hexadecimal 00H 6CH)

And so on...

2-4 Data address

Data address	Local address	Content		Read/write
2000H _48193	BIT0~BIT1	00B: none 10B: start	01B: stop 11B: JOG start	Write
	BIT2~BIT3	00B: none 10B: forward	01B: reverse 11B: change direction	Write
	BIT4	0B: none	1B: reset	Write
	BIT5~BIT15	Reserved		

2001H _48194	BIT0~BIT15	Frequency command 00000~40000 Second position of Decimal point (F1.01=5 this data can work)	Write
-----------------	------------	---	-------

2-4-1 Sample of using ASCII mode:

Preset:

F1.01 = 5 (frequency source);

F1.02 = 2 (control mode);

F7.00 = 1 (baud frequency 9600);

F7.01= 0 (8N1 FOR ASCII)

F7.02= 1 (address)

1. Setting frequency:

In 2001H unit to write into 50.00HZ (1388H)

Received word signal HEX:

3A 30 31 30 36 32 30 30 31 31 33 38 38 33 44 0D 0A

2. Operating command

In 2000H unit to write into 02H

Send word signal: ":010620000002 D7"CR LF

Send word signal HEX:

3A 30 31 30 36 32 30 30 30 30 30 30 32 44 37 0D 0A

Received word signal HEX:

3A 30 31 30 36 32 30 30 30 30 30 30 32 44 37 0D 0A

3. Stop operating order

In 2000H unit to write into 01H

Send word signal: ":010620000001 D8"CR LF

Send word signal HEX:

3A 30 31 30 36 32 30 30 30 30 30 30 31 44 38 0D 0A

Received word signal HEX:

3A 30 31 30 36 32 30 30 30 30 30 31 44 38 0D 0A

About the "44 38" calculation please follow the LRC in user's manual.

2-4-2 Sample of using RTU mode:

Preset:

F1.01 = 5 (frequency source);

F1.02 = 2 (control mode);

F7.00 = 1 (baud frequency 9600);

F7.01= 3 (8N1 FOR RTU)

F7.02= 1 (address)

Using RTU mode to control:

1. To set the frequency first:

In 2001H unit to write 50.00HZ (1388H)

Send word signal: 01 06 2001 13 88 CRCL CRCH

2. Operation command

In 2000 unit to write 02H

Send word signal: 06 2000 00 02 CRCL CRCH

3. Stop operation command

In 2000H unit to write 01H

Send word signal: 06 2000 00 01 CRCL CRCH

4. To set acceleration time F1.07=20.0S

In 107(6BH) unit to write in 200 (C8H)

Send word signal: 01 06 00 6B 00 C8 CRCL CRCH

Appendix 3 Common parameters for YMP series drives

NO	Code	Name	1T1	1T2	1T3	1T4	Value from the factory	Setting value	remark
1	F1.02	Setting selection	1	1	1	1	0	1	1: IO Terminal
2	F1.04	effectively setting for inversion	0	0	0	0	1	0	0: Prohibit reversal
3	F1.06	The frequency for minimum operating	0	0	0	0	0	0	
4	F1.07	the time of speeding up 1	10	10	10	10		10	10 seconds
5	F1.08	the time of reducing the speed 1	10	10	10	10		10	10 seconds
6	F1.18	Parameter locking						1	1: Parameter lock, setting on finally
7	F2.01	Parking mode	1	1	1	1	1	1	1 Free Parking
8	F3.15	Input Terminal FWD	6	6	6	6	6	6	6: The positive rotation
9	F3.17	Input terminal S1		27	27	27	7	19	Pump off the NO 1
10	F3.18	Input terminal S2		28	28	28	1	18	Pump off the NO 2
11	F3.19	Input terminal S3			29	29	18		Pump off the NO 3
12	F3.20	Input terminal S4				30	15		Pump off the NO 4
13	F3.21	Input terminal S5,PID Running						19	replacement the F6.00=1,Fire Frequency

NO	Code	Name	1T1	1T2	1T3	1T4	Value from the factory	Seeting value	remark
14	F6.00	PID opening modes	1	1	1	1	0	1	1. PID opening modes
15	F6.01	PID Running modes	0	0	0	0	0	0	0. Negative feedback model
16	F6.02	PID target selection	1	1	1	1	0	0	01: Choose the digital target value
17	F6.03	PID Feedback value selection	1	1	1	1	0	1	1: Select FIV as the feedback value
18	F6.20	KB1, KA1 Function Selection	2	2	2	2	2	2	2: The Frequency contact of motor A
19	F6.21	KB2, KA2 Function Selection	1	1	1	1	1	1	1: The Power Frequency contact of motor A
20	F6.22	KB3, KA3 Function Selection	4	4	4	4	4	4	4: The Frequency contact of motor B
21	F6.23	KB4, KA4 Function Selection	3	3	3	3	3	3	3: The Power Frequency contact of motor B
22	F6.24	KB5, KA5 Function Selection	6	6	6	6	6	6	6: The Frequency contact of motor C
23	F6.25	KB6, KA6 Function Selection	5	5	5	5	5	5	5: The Power Frequency contact of motor C
24	F6.26	KB7, KA7 Function Selection	8	8	8	8	8	8	8: The Frequency contact of motor D
25	F6.27	KB8, KA8 Function Selection	7	7	7	7	7	7	7: The Power Frequency contact of motor D

Appendix 3 Common parameters for YMP series drives

NO	Code	Name	1T1	1T2	1T3	1T4	Value from the factory	Seeting value	remark
26	F6.34	Type of A Pump	1	1	1	1	1	1	0:No effective of the water pump
27	F6.35	Type of B Pump	0	1	1	1	1	1	1: controller of the frequency
28	F6.36	Type of C Pump	0	0	1	1	0	0	2: Controller of the Power Frequency
29	F6.37	Type of D Pump	0	0	0	1	0	0	
30	F6.41	The difference of the value when pressure the pump	0	0	0	0	0	0	the target value for the reference for adding the pump
31	F6.42	Running frequency when pressure the pump		48	48	48	48	48	The running frequency for pressure the pump
32	F6.43	Delay the time when pressure the pump	0	2	2	2	8	8	The delay time for pressure the pump
33	F6.45	The difference of the value when reduce the pump		0	0	0	2	5	the target value for the reference for reducing the pump
34	F6.46	Running frequency when reduce the pump		35	35	35	35	30	The running frequency for reduce the pump
35	F6.47	Delay the time when reduce the pump	0	2	2	2	2	10	The delay time for reduce the pump
36	F6.51	time of Circulate	240	240	240	240	480	480	changing the pump on timing :minute

Operation Instruction of YMP Series Inverter

NO	Code	Name	1T1	1T2	1T3	1T4	Value from the factory	Seeting value	remark
37	F6.60	target value for precessuring	20	20	20	20	20		the range percentage according to the precessure,the total range is 100%
38	F6.68	The time selection for dormancy	255	255	255	255	0	255	dormancy any time .
39	F6.69	The difference of the value for pressure of dormancy	2	2	2	2	5	2	0~25
40	F6.70	duration of the dormancy	10	10	10	10	10	30	Dormancy condition judgement frequency
41	F6.71	Frequency of the dormancy	30	30	30	30	35	28	The delay time which is lower than the frequency of dormancy
42	F6.73	The difference of the value for pressure of waken up	2	2	2	2	5	5	0~25
43	F6.74	time of waken up	2	2	3	3	3	3	0~3600.0S

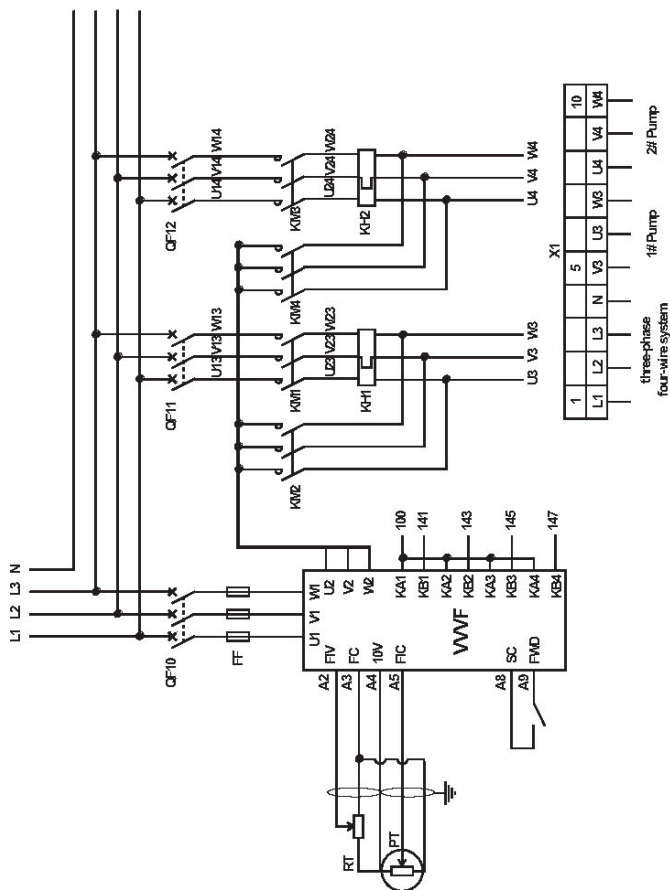

1T2 Electrical schematics

Auto Run	# Pump By Hand Run	Breakdown Alarming	Source sink level too low	water pump overload	Power instruct
Run	By Hand Run				

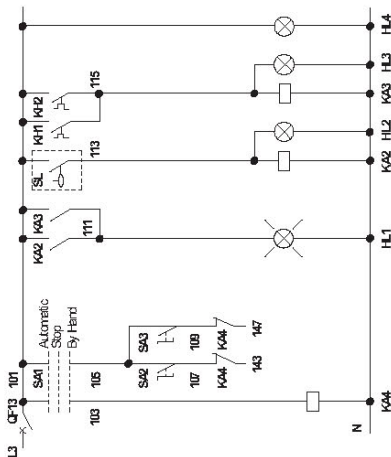

to panel board

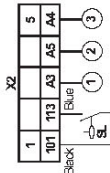
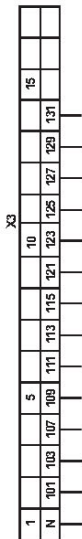

Connect the pressure gauge

1T2 Electrical schematics

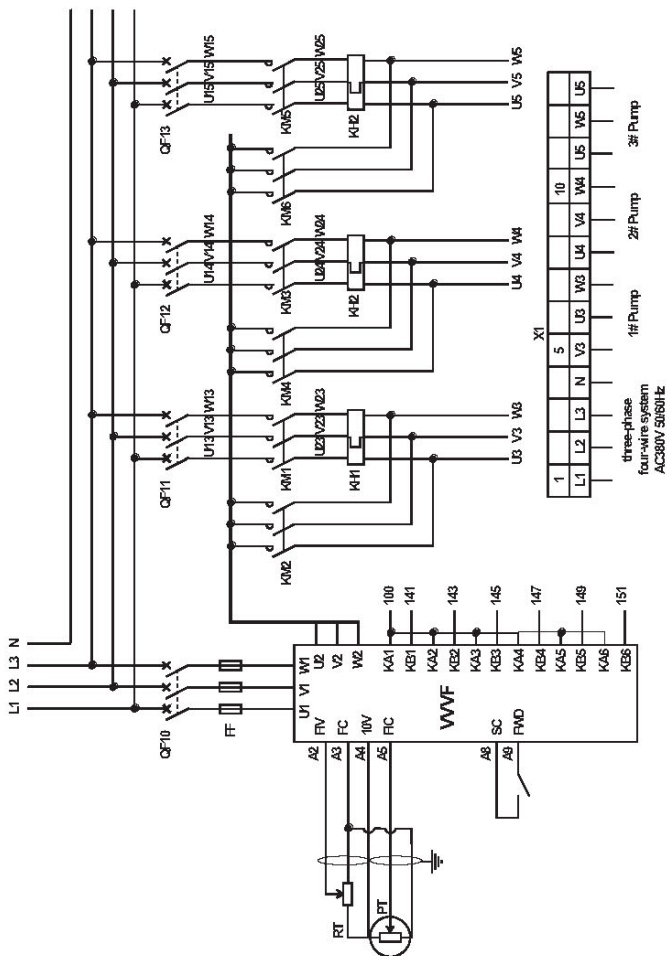

1T3 Electrical schematics

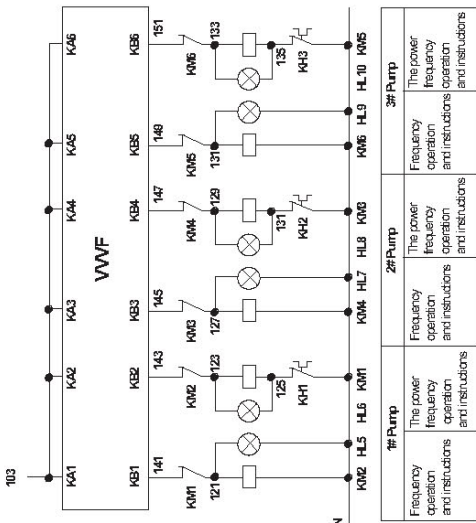
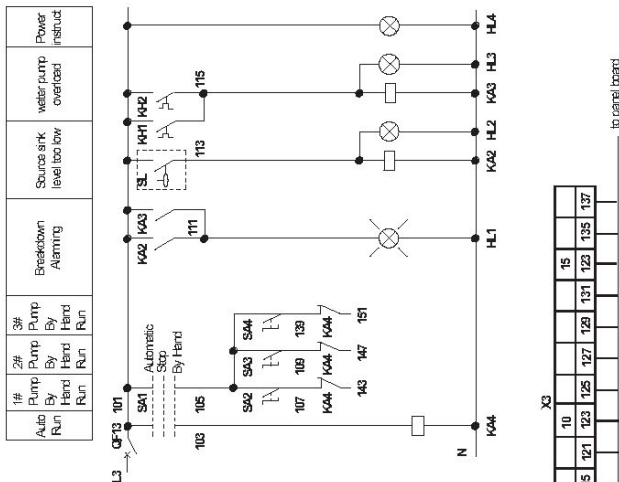

1T3 Electrical schematics

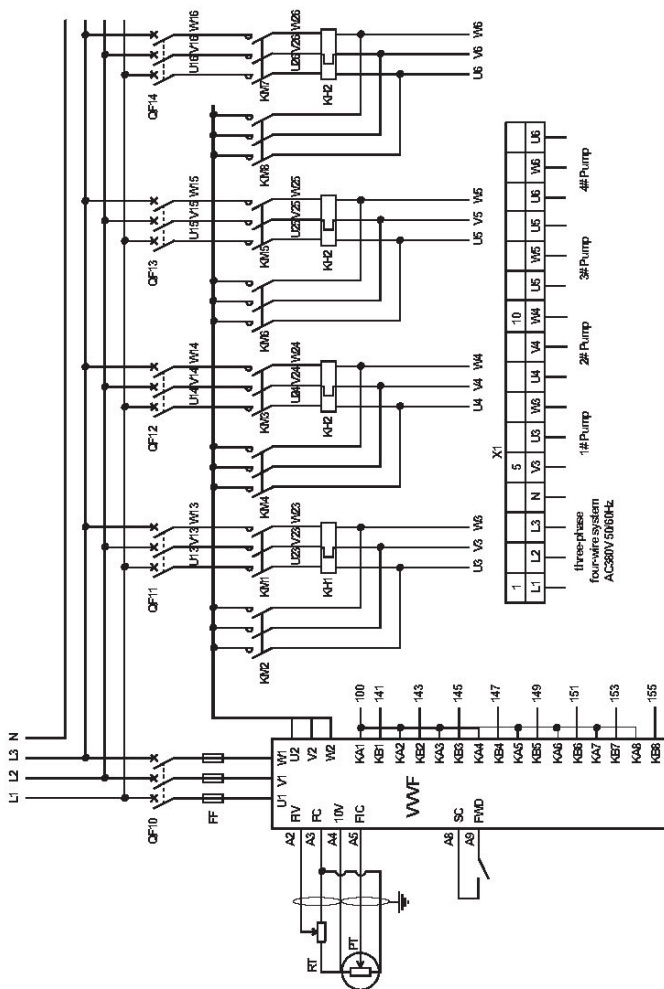

1T4 Electrical schematics



YILMAZ REDÜKTÖR AŞ

Atatürk Mh. Lozan Cd. No:17,
34522 Esenyurt/İstanbul – Türkiye

Tel: +90 212 886 90 00

e-Mail: otomasyon@yr.com.tr